

# Design and Realization of a Smart Battery Management System

C. Chen, K.L. Man, T.O. Ting, Chi-Un Lei, T. Krilavičius,  
T.T. Jeong, J.K. Seon, Sheng-Uei Guan and Prudence W.H. Wong

**Abstract**—Battery management system (BMS) emerges a decisive system component in battery-powered applications, such as (hybrid) electric vehicles and portable devices. However, due to the inaccurate parameter estimation of aged battery cells and multi-cell batteries, current BMSs cannot control batteries optimally, and therefore affect the usability of products. In this paper, we proposed a smart management system for multi-cell batteries, and discussed the development of our research study in three directions: i) improving the effectiveness of battery monitoring and current sensing, ii) modeling the battery aging process, and iii) designing a self-healing circuit system to compensate performance variations due to aging and other variations.

**Index Terms**—Battery management system (BMS), multi-cell batteries, multi-cell, battery aging, self-healing circuit.

## I. INTRODUCTION

IN the 21<sup>st</sup> century, transportation and environment problems are the primary challenge for many countries, especially for China. Due to the increasing awareness of global warming, the demand for clean fuel/energy is on the rise. Thus, there is a continuous shift towards the Electric Vehicles (EVs) and Hybrid Electric Vehicles (HEVs) [1]. Moreover, battery-powered electronic devices have become ubiquitous in modern society. Rapid expansion of the use of portable devices (e.g. laptops, tablet computers and cellular phones) creates a strong demand for a large deployment of battery technologies at an unprecedented rate. In addition, distinct requirements for batteries, such as high energy storage density, no-memory effect, low self-discharge and

long cycling life, have drawn explicit attention recently. Due to the above-mentioned facts, battery management systems (BMSs) become indispensable for modern battery-powered applications [19-21].

An effective BMS can protect the battery from damage, predict battery life, and maintain battery operability. Technically, BMS can maximize the run-time per discharge cycle and the number of life cycles attainable for the battery. This is achieved by monitoring the charging and discharging process of the battery through status of the state of charge (SoC), state of health (SoH) and remaining useful life of the battery [2]. Typical (multi-cell) battery contains a battery (cell pack with cell switching circuit) and a BMS; and connects to load and charger, as shown in Fig. 1.

Reliability of batteries directly affects the usability and performance of the EVs/HEVs and other battery-powered electronic devices. However, due to the aging process, parameters of batteries are usually non-linear and time-dependent. Furthermore, traditional BMSs cannot detect battery states and manage battery operations in a real time manner [3]. These issues become even more prevalent in multi-cell battery systems. However, such issues are not explicitly explored by research communities. Eventually, they will affect the usability of battery-powered products.

In this paper, we discuss our current study about a smart BMS for aged batteries and multi-cell batteries. Discussions on our research studies are carried out in three directions: i) improving the functionality and effectiveness of the monitoring process through a hybrid decision methodology, ii) modeling the battery aging process through an experimental aging testing method and emerging modeling techniques, and iii) designing a self-healing (self-reconfigured) circuit system to compensate performance variations due to cell aging and variations in sub-micron technologies.

## II. BATTERY MONITORING

In this section, we first discuss two performance indicators in the battery monitoring process. This is followed by the instrumentation in the monitoring process, and the monitoring of multi-cell battery systems.

### A. State of Charge and State of Health

SoC represents the present capacity of the battery expressed in terms of its rated capacity [5-14,36,37]. Accurate SoC is needed in the control circuit to ensure optimum control of the charging process. Knowledge of SoC of battery or individual cells is required for many applications, such as for guidance

Manuscript received January 12, 2012.

C. Chen is with the Global Institute of Software Technology, China. Email: ccsz@gist.edu.cn

K.L. Man is with the Xi'an Jiaotong-Liverpool University, China, Myongji University, South Korea and Baltic Institute of Advanced Technology, Lithuania. Email: ka.man@xjtlu.edu.cn

T.O. Ting and Sheng-Uei Guan are with the Jiaotong-Liverpool University, China. Email: {toting, steven.guan}@xjtlu.edu.cn

C.-U. Lei is with the University of Hong Kong, Hong Kong. Email: culei@eee.hku.hk

T. Krilavičius is with the Vytautas Magnus University and Baltic Institute of Advanced Technology, Lithuania. Email: t.krilavicius@bpti.lt

T.T. Jeong is with the Myongji University, South Korea. Email: ttjeong@mju.ac.kr

J.K. Seon is with the LS Industrial Systems, South Korea. Email: jkseon@lisis.biz

Prudence W.H. Wong is with the University of Liverpool, U.K. Email: pwong@liverpool.ac.uk

The research work presented in this paper is partially sponsored by SOLARI (HK) CO (www.solari-hk.com) and KATRI (www.katri.co.jp and www.katri.com.hk). Also, this paper is supported by the project VIZIT-1-TYR-003 (VP1-3.1-ŠMM-01-V-02-001), Research Council of Lithuania.

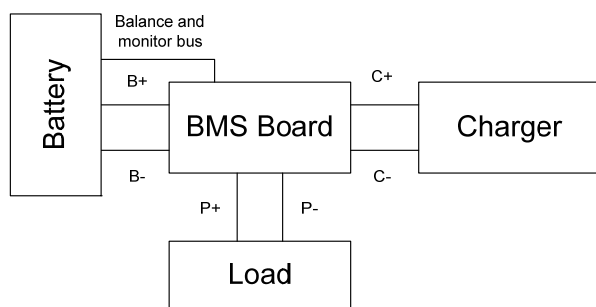

Fig. 1. Block diagram of a typical battery management system.

on optimal usage of the battery-powered device/application. Many techniques have been proposed for generic real-time SoC determinations:

- 1) Fuzzy Logic [4,12] uses battery parameters to estimate SoC accurately through data approximations. However, its membership function is highly subjective, and therefore, it requires a lot of memory in practices.
- 2) Kalman Filter [4,11,31] can determine SoC accurately, especially for systems with multiple inputs, through stripping unwanted noise out of a set of data. However, it is difficult to implement the filtering algorithm that complies with specific requirements, such as non-normalities and non-linearities.
- 3) Artificial Neural Networks (ANN) [4,31] determine SoC through pattern sorting, learning from trial and error, discerning and extracting relationships. It can model linear and nonlinear relationships; however, ANN needs training data of a similar battery and is expensive to implement [40].

State of Health (SoH) is a measurement that reflects the general condition of a battery and the ability to deliver a specified output. It also indicates the remaining useful lifetime and maintenance status of the battery. SoH measurement is important for assessing the readiness of emergency power equipments. In practice, SoH can be estimated by a single measurement of conductance or impedance of the cell, which is easy but imprecise.

In our study, we aim to develop efficient and accurate SoC and SoH estimation algorithms through hybrid approach using ant colony optimization [9] and fuzzy logic. Furthermore, cell/battery parameters, such as capacity, internal resistance, self-discharge, charge acceptance, discharge capabilities, will be used in proposed algorithms to estimate the actual SoH in a comprehensive perspective.

### B. Lossless Current Sensing and Feedforward Control

Current sensing [38] is fundamentally required by a wide range of electrical operations, for example, monitoring of battery life and battery currents. Conventionally, current is sensed by inserting a resistor in the target path. This method incurs significant power losses, especially in high-current applications. Lossless current-sensing methods [38] address this issue by sensing the current without consuming the power as in the case of passive resistors. However, their accuracies are significantly lower than conventional approaches. Moreover, lossless methods are generally and inherently less susceptible to switching noise. Therefore, noise removal and precision enhancement are two issues in lossless current sensing that have a high research value. In

this study, we propose *feedforward* control to address these issues.

Feedforward control can effectively eliminate or reduce effects of disturbances in a control system. It is also very useful in systems with time-varying references that cannot be adequately tracked by feedback control. Load-current feed-forward control has been shown to be a promising technique that can eliminate the stability constraint linking the size of the output capacitor and the switching frequency of typical digital controllers and power converters [39]. Over the past years, load-current feed-forward control has been widely applied for current sensing [39]. However, there are several issues that impair the use of load-current feedforward control for current sensing. For instance, the aggressive load current transient (e.g. with the slew rate of 1A/ns) requires fast sampling and processing of the load current. Another issue is the large dynamic range requirement by directly quantizing the load current over a wide load range.

In our study, we aim to develop lossless current sensing techniques that can have an efficient and high-precision current-mode control in harsh environments. In implementation, we start by developing the feedforward control with a fast processing of load current through a relaxation of sampling speed.

### C. Management of Multi-Cell Batteries

Due to the production tolerances or operating conditions of batteries, there are small differences in charges between cells that may be magnified with each charge-discharge cycle. During charging, weak cells become overstressed, thus cause a further degradation. Weak cells eventually start malfunctioning, and cause a premature failure of the whole battery system. In order to extend the lifetime of (multi-cells) battery systems, dedicated battery management approaches should be developed. For example, weak cells can be compensated by equalizing the charge on each cell in the battery chain [31].

One of the prime functions of the multi-cells BMS is to monitor and control battery cells systemically, in order to protect battery cells and battery systems from abnormal ambient or operating conditions. This function is particularly important in automotive applications because they work in the harsh environment with high temperature and high vibration [31]. For this research, we aim to design individual cell protection for automotive systems in order to avoid the external fault conditions. This can be done by isolating the battery as well as addressing the fault. For example, the cooling fan should be turned on if the battery overheats, and if the battery is excessively and continuously overheated, the battery should be disconnected.

## III. BATTERY AGING PROCESS

Performance of batteries, especially rechargeable batteries, deteriorates and loses their storage capacity gradually, due to irreversible physical changes and chemical changes within the battery. For example, surface area of battery cell plates shrinks continuously and permanently because of plate corrosions. Thus, the electrolyte becomes less reactive, and the charge capacity of the cell is reduced. Moreover, the internal resistance of the cell also increases because corrosion

products inhibit the free flow of electrons through plates and electrolytes.

Batteries deteriorate regardless of whether they are used or not. However, battery degradation is strongly influenced by charge/discharge conditions, electrolyte decomposition and the formation of surface films on both electrodes [32]. These aging processes take place due to complex operation conditions [23-25]. Some common conditions are outlined here:

- 1) Temperature of batteries during charging and discharging: Most corrosion occurs during cycles of charging and discharging, and accelerates at a higher temperature. Therefore, batteries usually operate in a restricted temperature range during the charging cycle. If it is possible, charging should be performed in a lower temperature environment. For example, studies state that 15°C is optimal for battery charging [33]. For another example, after a high current consumption, the battery should be cool down before (re-)charging.
- 2) Discharge depth: It will shorten the time in both charge and discharge cycles because of the internal battery resistances and batteries heats during operations. This factor might not be as obvious but more frequent battery changes will increase the overall lifespan of the Lithium-ion battery.
- 3) Charging voltages: Charging voltages have a significant effect on battery longevity. Some cells may deteriorate faster than others during operations. Deteriorated cells reduce the output voltage of the battery, and affect the usability and reliability of the circuit. This issue is more apparent for high-current applications, since the voltage drop is magnified due to the internal resistance. Also, such an issue causes the battery to appear to the user to have less capacity as its cells age.

Battery aging is a complex process which requires a sophisticated modeling technique. A battery aging model of Ni-MH batteries has been proposed in [30]. Meanwhile, the influence of battery aging on the electromotive force has been discussed in [31]. Since deterministic models have a weak functionality and versatility, different probabilistic/stochastic models, Markovian decision processes and formal models have been proposed recently [18,22,34,35] that can be used to deal with uncertain or incomplete information, employing concepts from probability.

Based on the existing study, we aim to i) study battery aging process with respect to chemical changes and physical conditions of batteries, ii) adopt continuous models, probabilistic models, stochastic models and hybrid models for a more realistic battery modeling, and iii) develop charging/discharging algorithms that alleviate the aging process through artificial intelligent and/or formal approach. In implementation, we will first design an accelerated life test to understand the aging processes of battery, and then develop modeling and charging/discharging algorithms in the second stage.

#### IV. HARDWARE IMPLEMENTATION OF BATTERY MANAGEMENT SYSTEM:

Rechargeable battery systems have been widely used in

different applications. Multi-cell battery management system has been proposed due to manufacturability and safety of battery cells [15-17,26-28]. Thus, battery management integrated circuit (BMIC) is combined with cell packs, sensors and main processors; in order to monitor and schedule the operation of each battery cells. Fixed-configuration battery systems are widely used in practice, but they usually behave abnormally in extreme conditions such as high temperature, over-charged and over-discharged. Also, they usually have low conversion efficiency and a non-optimal system performance. Safety circuits have been proposed to protect the battery system by switching off the whole system. However, they cannot fully utilize the battery system. Therefore, they are not capable to improve functionality, lifespan and conversion efficiency of battery systems. Recently, some configurable methodologies have been proposed. Those methodologies can dynamically configure the battery system in series and parallel; therefore they can output the required current and voltage with a better conversion efficiency and functionality. However, battery aging and other physical/chemical nondeterministic characteristics of the battery system significantly affect the battery system performance such as power quality and battery lifespan. In addition, existing approaches still cannot overcome these deficiencies, and cannot fully utilize the energy usage of battery systems with aged problem or operation in the extreme environment.

In this research study, self-calibrated battery management system is proposed for multi-cell battery systems. Battery system operation status is observed through sensors and analyzed through processors. Tuning knobs of the battery system are adjusted in order to calibrate internal circuit parameters (e.g. bias current/voltage, programmable delay/frequency) and compensate the performance variations due to aging and other variations. The developed system can improve the yield and lifetime of the system when battery cells in the battery system encountering problems of battery aging or other variational faults. The developed system will also have a self-diagnosis process with a flag indication (complete, partial and fail) of the re-configuration process for user practicability.

This study can be divided into the following tasks:

- 1) developing monitoring, scheduling and re-configuration algorithms to monitor the BMS performance and determining the compensation for the degraded performance;
- 2) developing a configurable power converter circuit topology to calibrate the battery cell status and improving the delivered power quality;
- 3) implementing the BMS system using battery cell network, mixed-signal FPGA boards (or FPAA boards), power MOSFETs, microcontroller and other peripherals;
- 4) analyzing and optimizing the BMS performance of i) power supply performance in terms of output energy usage and lifespan, and ii) the re-configuration process in terms of convergence and stability.

In implementation, we aim to i) design and validate the BMS performance in Matlab/Simulink environment, ii) construct a prototype in hardware and test it via variable DC

sources and programmable DC electronic loads, and iii) realize the proposed BMS as a IC chip package.

## V. CONCLUSION

In this paper, research issues and research problems related to multi-cell battery management system design have been discussed comprehensively. Based on the study, we aim to develop battery monitoring algorithms with advanced aged battery models, as well as efficient lossless current sensing methodologies and self-healing battery management hardware systems that can prolong system runtime and battery lifetime.

## REFERENCES

- [1] Li Abhijeet Chandratre, Himanshi Saini, Sai Hanuma Vemuri, M.B. Srinivas, "Battery management system for E-bike: A novel approach to measure crucial battery parameters for a VRLA battery," In Power Electronics (ICPE), 2010 India International Conference, pp. 1-5, Jan. 2011.
- [2] Bharath Pattipati, Krishna Pattipati, Jon P. Christopherson, Setu Madhavi Namburu, Danil V. Prokhorov and Liu Qiao, "Automotive Battery Management Systems," AUTOTESTCON, IEEE, pp. 581-586, May 2008.
- [3] Li Yuheng, Wei Xuezhe and Sun Zhechang, "Low Power Strategy Design for Battery Management System," Measuring Technology and Mechatronics Automation, ICMTMA '09. International Conference, pp.636 - 639, Aug. 2009.
- [4] Bharath Pattipati, Chaitanya Sankavaram, and Krishna R. Pattipati, "System Identification and Estimation Framework for Pivotal Automotive Battery Management System Characteristics," IEEE Transactions on Systems, Man and Cybernetics. Part C, Applications and reviews, vol. 41, no.6, pp. 869-884, 2011.
- [5] A. Affanni, A. Bellini, G. Franceschini, P. Guglielmi, and C. Tassoni, "Battery choice and management for new-generation electric vehicles," IEEE Trans. Ind. Electron., vol. 52, no. 5, pp. 1343-1349, Oct. 2005.
- [6] Z. Yang, H. Hao, X. Guoqing, and Z. Zhiguo, "Hardware-in-the-loop simulation of pure electric vehicle control system," in Proc. Int. Asia Conf. CAR, pp. 254-258, 2009.
- [7] L. Maharjan, S. Inoue, H. Akagi, and J. Asakura, "State-of-charge (SOC)-balancing control of a battery energy storage system based on a cascade PWM converter," IEEE Trans. Power Electron., vol. 24, no. 6, pp. 1628-1636, Jun. 2009.
- [8] H. Dai, X. Wei, and Z. Sun, "Model-based SOC estimation for high-power Li-ion battery packs used on FCHVs," High Technol. Lett., vol. 13, no. 3, pp. 322-326, 2007.
- [9] Hedingrun, Liuxiaoyun and Chengdongyi, "Ant algorithms for power management system of wearable computer," in Proc. IEEE International Symposium on Communications and Information Technology, pp. 18-21, Oct. 2005.
- [10] B. S. Bhangu, P. Bentley, D. A. Stone, and C. M. Bingham, "Nonlinear observers for predicting state-of-charge and state-of-health of lead-acid batteries for hybrid-electric vehicles," IEEE Trans. Veh. Technol., vol. 54, no. 3, pp. 783-794, May 2005.
- [11] D.V. Do, C. Forgez, K. K. Benkara, and G. Friedrich, "Impedance observer for a Li-ion battery using Kalman filter," IEEE Trans. Veh. Technol., vol. 58, no. 8, pp. 3930-3937, Oct. 2009.
- [12] K. Goser, K. Schuhmacher, M. Hartung, K. Heesche, B. Hesse, and A. Kanstein, "Neuro-fuzzy systems for engineering applications," in Proc. IEEE AFRICON, vol. 2, pp. 759-764, 1996.
- [13] B. Saha, K. Goebel, S. Poll, and J. Christopherson, "Prognostics methods for battery health monitoring using a Bayesian framework," IEEE Trans. Instrum. Meas., vol. 58, no. 2, pp. 291-296, Feb. 2009.
- [14] C. R. Gould, C. M. Bingham, D. A. Stone, and P. Bentley, "New battery model and state-of-health determination through subspace parameter estimation and state-observer techniques," IEEE Trans. Veh. Technol., vol. 58, no. 8, pp. 3905-3916, Oct. 2009.
- [15] Y.-J. Lee, A. Khaligh, and A. Emadi, "Advanced integrated bidirectional AC/DC and DC/DC converter for plug-in hybrid electric vehicles," IEEE Trans. Veh. Technol., vol. 58, no. 8, pp. 3970-3980, Oct. 2009.
- [16] H. L. Chan, K. W. E. Cheng and D. Sutanto, "Phase-shift controlled DC-DC converter with bidirectional power flow," Proc. Inst. Elect. Eng.—Elect. Power Appl., vol. 148, no. 2, pp. 193-201, Mar. 2001.
- [17] L. Solero, "Nonconventional on-board charger for electric vehicle propulsion batteries," IEEE Trans. Veh. Technol., vol. 50, no. 1, pp. 144-149, Jan. 2001.
- [18] A. Szumanski and Y. Chang, "Battery management system based on battery nonlinear dynamics modeling," IEEE Trans. Veh. Technol., vol. 57, no. 3, pp. 1425-1432, May 2008.
- [19] S. Duryea, S. Islam and W. Lawrance, "A battery management system for stand-alone photovoltaic energy systems," IEEE Ind. Appl. Mag., vol. 7, no. 3, pp. 67-72, Jun. 2001.
- [20] B. Hauck, BATTMAN—A Battery Management System, Milan, Italy, 1992.
- [21] A. Affanni, A. Bellini, G. Franceschini, P. Guglielmi and C. Tassoni, "Battery choice and management for new-generation electric vehicles," IEEE Trans. Ind. Electron., vol. 52, no. 5, pp. 1343-1349, Oct. 2005.
- [22] R. Peng and M. Pedram, "Battery-aware power management based on Markovian decision processes," IEEE Trans. Computer Aided Design Integr. Circuits Syst., vol. 25, no. 7, pp. 1337-1349, Jul. 2006.
- [23] A. Mills and S. Al-Hallaj, "Simulation of passive thermal management system for lithium-ion battery packs," J. Power Sources, vol. 141, no. 2, pp. 307-15, Mar. 1, 2005.
- [24] Bloom, J. J., Sohn S. and A. Jones "An accelerated calendar and cycle life study of Li-ion cells," Journal of Power Sources, vol. 101, pp. 238-247, 2001.
- [25] E. V. Thomas, H. L. Case and D. H. Doughty, "Accelerated power degradation of Li-ion cells," Journal of Power Sources, vol. 124, pp. 254-260, 2003.
- [26] Mandal, S.K., Mahapatra, R.N., Bhojwani, P.S. and Mohanty S.P., "IntellBatt: Toward a Smarter Battery," Computer, vol. 43, no.3, pp.67-71, March 2010.
- [27] Taesic Kim, Wei Qiao and Liyan Qu, "Self-reconfigurable multicell batteries," Energy Conversion Congress and Exposition (ECCE), 2011 IEEE, pp. 3549-3555, Sept. 2011.
- [28] Smart Battery System Implementers Forum, SBS Specifications; <http://sbs-forum.org/specs>.
- [29] Lorenzo Serrao, Zakaria Chehab and Giorgio Rizzoni, "An Aging Model of Ni-MH Batteries for Hybrid Electric Vehicles," [http://www.ni-cd.net/accusphp/forum/docjoints/ID214\\_methode%20Nimh.pdf](http://www.ni-cd.net/accusphp/forum/docjoints/ID214_methode%20Nimh.pdf).
- [30] V. Pop, H. J. Bergveld, P. P. L. Regtien, J. H. G. Op het Veld, D. Danilov and P. H. L. Notten, "Battery Aging and Its Influence on the Electromotive Force," Journal of The Electrochemical Society, vol. 154, no. 8, pp. 744-750, May 2007.
- [31] "Battery Management Systems (BMS)," <http://www.mpoweruk.com>
- [32] Pop V., Bergveld, H.J., Danilov, D., Regtien, P.P.L. and Notten, P.H.L., Battery Management Systems: Accurate State-of-Charge Indication for Battery-Powered Applications. Philips Research Book Series 9. Springer Verlag, London, 2008.
- [33] Pawanjot Multani, "Lithium Ion Battery Aging Factors," <http://community.pson.com/knowledge/w/knowledgebase/lithium-ion-battery-aging-factors.aspx>
- [34] A. Acquaviva, A. Aldini, M. Bernardo, A. Bogliolo, E. Bontà and E. Lattanzi, "A Methodology Based on Formal Methods for Predicting the Impact of Dynamic Power Management," Formal Methods for Mobile Computing - Lecture Notes in Computer Science, Vol.3465, pp.51-58, 2005.
- [35] Lungu Anita, Bose Pradip, Sorin Daniel J., German Steven and Janssen Geert, "Multicore power management: Ensuring robustness via early-stage formal verification," IEEE/ACM International Conference on Formal Methods and Models for Co-Design, pp.78-87, 13-15, July 2009.
- [36] A. Hussein and I. Batarseh, "A Review of Charging Algorithms for Nickel and Lithium Battery Chargers," IEEE Trans. Veh. Technol., vol.60, no.3, pp.830-838, March 2011.
- [37] B. Xiao, Y. Shi and L. He, "A universal state-of-charge algorithm for batteries," ACM/IEEE Design Automation Conference (DAC), pp.687-692, 13-18 June 2010.
- [38] Y. Zhang, R. Zane, A. Prodic, R. Erickson, and D. Maksimovic, "Online calibration of MOSFET on-state resistance for precise current sensing," IEEE Power Electron. Lett., 2(3):100-103, September 2004.
- [39] A.V. Peterchev and S.R. Sanders, "Load-Line Regulation with Estimated Load-Current Feedforward: Application to Microprocessor Voltage Regulators," IEEE Transactions on Power Electronics, vol.21, no.6, pp.1704-1717, Nov. 2006.
- [40] S. Piller, M. Perrin and A. Jossen, "Methods for state-of-charge determination and their applications," J. Power Sources, vol.96, pp. 113-20, 2001.