

VHDL Implementation of Multiplierless, High Performance DWT Filter Bank

Mr. M.M. Aswale¹, Prof. Ms. R.B Patil², Member ISTE

Abstract—The JPEG 2000 image coding standard employs the biorthogonal 9/7 wavelet for lossy compression. The performance of hardware implementation of 9/7-filter bank depends on accuracy and efficiency. A method for processing signal in a canonical signed digit format, filter due to fractional coefficient includes the steps of obtaining real coefficients optimized to desired filter characteristics, calculating scaling factors for each real coefficients which minimizes errors between the real coefficients and converted canonical signed digit codes, producing optimum canonical signed digit coefficients by using the calculated scaling factors and filtering input data by using the optimum canonical signed digit form coefficient. For multiplierless operation canonical sign digit plays an important roll in processing signal. Advantage of this implementation is to reduce the number of adders in hardware and also increase the speed of operation. Filter bank filters the low resolution information using lowpass filter and high resolution information by using high pass filter. Wavelet co-efficient decides the characteristic of filter. In this method we used 9/7 wavelet transform to implement multiplierless operation.

To implement multiplierless Hardware we used sum or difference of power two-representation i.e. canonical signed digit form. The canonical signed digit form is optimal in terms of how many nonzero digits are required to represent a given number. On an average, a canonical representation used two thirds as many nonzero digits as a binary representation, so the canonical signed digit form can significantly reduce the number of adders required in hardware.

Keywords - Biorthogonal 9/7, canonical sign digit, multiplierless

I. INTRODUCTION

Many image and video compression techniques are based on the discrete wavelet transform (DWT). A great number of analysis/synthesis filters for the DWT have been proposed past. However Antonini's 9/7 filter [1] is most popular one, since it combines good performance and rational filter length. It is stressed have that 9/7 filter is default filter of the upcoming JPEG 2000.[2] standard and included in MPEG4 [3] standard.

Manuscript received December 15, 2006. This work was supported in part by the circular No. ASS/2005-06/251 dt 14/02/06

Mr. M.M Aswale¹ is with the Deptt. of Electronics and Communication Engineering, G.H. Raisonni College of Engineering,Nagpur-16, INDIA. (e-mail: mohan_ghrp@yahoo.com).

Ms.R. B. Patil², is with the Deptt. of Electronics and Communication Engineering,G.H.Raisonni College of Engineering,Nagpur-16, INDIA. (email: rupali_patil@rediffmail.com).

A digital filter is most important and most frequently used element in processing a digital signal and includes delays, multipliers and adders. The simplest form of digital filter is multiplier with number of delays. This type of filter is generally used for processing a signal such as controlling gains. The digital filter is generally comprised of a plurality of multipliers, which occupy large areas and consume much power, impose constraints on a one-chip solution when circuits are integrated. In this aspect, efforts have been expanded to reduce the associated hardware complexity by simplifying multipliers used in such digital filters. To avoid multipliers we give preference to canonical signed digit form in FIR filter structure. The present invention relates to method for processing image in a filter employing canonic signed digit (CSD) code and circuit suitable for the method, which can improve performance of the filter and can be adapted to many kinds of filters by increasing resolution of scaling factors [3]. A fast, efficient, multiplierless high-performance implementation of biorthogonal 9/7 discrete wavelet transform (DWT) on a field programmable gate array (FPGA) is described. The structure of one stage of two-channel biorthogonal filter bank used to compute the DWT is shown in fig1. In a biorthogonal filter bank all the filters are finite impulse response (FIR) and symmetric. The synthesis section of a filter bank inverts the analysis section, assuming PR, the reconstructed image will equal original image. This occurs when the following PR conditions met [3].

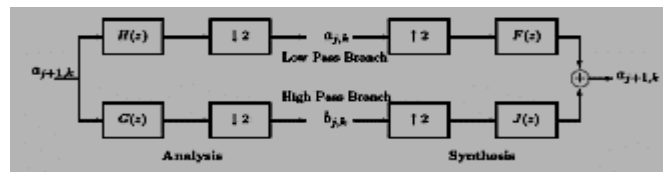

Fig.1. Two-channel biorthogonal wavelet filter bank.

$$F(z)H(z)+J(z)G(z)=2z^{-1} \quad (1)$$

$$F(z)H(-z)+J(z)G(-z)=0 \quad (2)$$

The performance of a hardware implementation of filter bank depends on how well the two PR conditions and linear phase are preserved. The no aliasing condition of equation (2) is satisfied by design in the usual way

$$\begin{aligned} g(n) &= (-1)^n f(n) & G(z) &= F(-z) \\ j(n) &= -(-1)^n h(n) & J(z) &= -H(-z) \end{aligned} \quad (3)$$

These relationship reduces the problem from the design of four filters to the design of just two, once the two lowpass filters (LPF's) are designed, the high pass filters (HPF's) are derived from equations (3).[4]. In this paper aspect related to filter coefficient quantization and hardware architecture of filtering unit exhaustively explored. Paper is divided into four sections. Section II focus on lifting scheme approach, Section III Convolution filter approach and Section IV result and comparison. For each case the effect of filter coefficient quantization in performance in terms of peak signal to noise ratio (PSNR) is presented. Experimental results concerning the PSNR have been acquired by running row- column implementation of filter under test. The filter alternatives are mapped on an FPGA using a prototyping platform hosting on Altera.

II. THE LIFTING SCHEME APPROACH

The lifting scheme based DWT has been included in the upcoming JPEG 2000 standard because it reduces the arithmetic complexity [5]. The lifting based DWT implementation of filtering as described [2] is given bellow. Applying the following steps to the entire input performs the transformation. The input is extended before and after the first and last coefficient.

Forward transformation

$$\begin{aligned} Y_{2n+1} &= X_{2n+1} + \alpha * (X_{2n} + X_{2n+2}) \\ Y_{2n} &= X_{2n} + \beta * (Y_{2n-1} + Y_{2n+1}) \\ Y_{2n+1} &= Y_{2n+1} + \gamma * (Y_{2n} + Y_{2n+2}) \\ Y_{2n} &= Y_{2n} + \delta * (Y_{2n-1} + Y_{2n+1}) \\ Y_{2n+1} &= Y_{2n+1} * -K \\ Y_{2n} &= Y_{2n}/K \end{aligned}$$

Inverse Transformation

$$\begin{aligned} x_{2n} &= Y_{2n} * K \\ x_{2n+1} &= -Y_{2n+1}/K \\ x_{2n} &= X_{2n} - \delta * (X_{2n-1} + X_{2n+1}) \\ x_{2n+1} &= X_{2n+1} - \gamma * (X_{2n} + X_{2n+2}) \\ x_{2n} &= X_{2n} - \beta * (X_{2n-1} + X_{2n+1}) \\ x_{2n+1} &= X_{2n+1} - \alpha * (X_{2n} + X_{2n+2}) \end{aligned}$$

Where the values of the constants are

$$\begin{aligned} \alpha &= -1.586134342 \\ \beta &= -0.052980118 \\ \gamma &= 0.882911075 \\ \delta &= 0.413506852 \end{aligned}$$

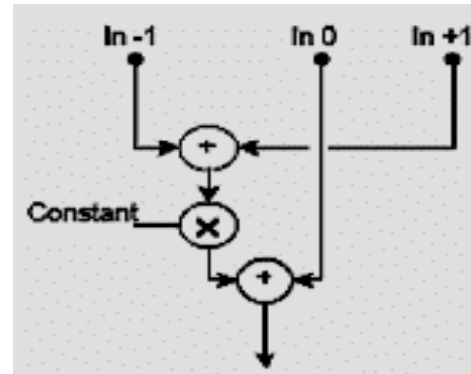

Fig.2. Basic processing block of lifting scheme

A. Quantization of Constant

The 9/7 filter is originally based on a floating point data representation. Since the scope here is hardware implementation of 9/7 filter. We focus of equivalent filter that uses fixed point (FXP) data representation. This is due to the feel that floating-point data path operators are more complex, occupy more area and are slower than their fixed point counterparts. The aim of this subsection is to define the effect of quantization of the fixed point representation of samples and filter constants on image quality in terms of PSNR, and filter implementation in terms of speed and area. The following results for the PSNR achieved by different quantization of the constant are obtained using two test images: Lena (512 x 512 x 8) and bridge (512 x 512 x8). The forward filter is a hardware implementation using the constants above. For the inverse filtering two types of filter are used. A software double precision filter with no quantization error and a hardware implementation using quantized constant.

TABLE I
PSNR measurement

Inverse type	Image	Levels					
		1	2	3	4	5	6
Software (double preci)	Lena	∞	∞	∞	∞	∞	80db
	Bridge	∞	∞	∞	65db	58db	50db
Hardware implementation	Lena	∞	∞	∞	∞	73 db	56 db
	Bridge	∞	∞	∞	∞	71 db	53 db

B. Architecture for lifting scheme processing

1) Optimized using shift-add operation

Using shift-add operations to replace the multiplications with constant optimizes the multiplier implementation. An improved processing block can be obtained that way but a separate block is needed to perform the multiplication with each constant. The architecture of the optimized processing unit is shown is fig.3

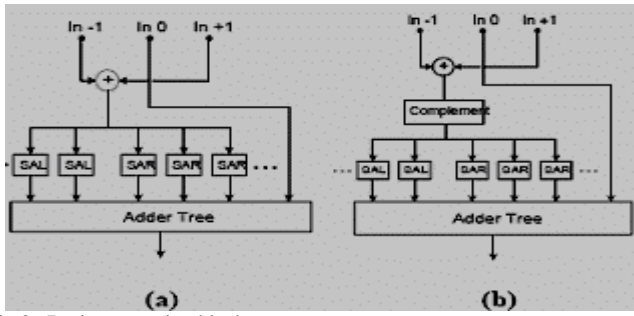

Fig.3. Basic processing block
 a) Positive constant
 b) Negative constant

Two different architectures are given depending on the constants sign. The multiplication with constant is translated in summing shifted version of input. When the positive constant is in fixed point format a term corresponding to each bit with value for example, multiplication with constant 2.25 which is represent in fixed point format as 0010.0100 equivalent in adding two terms The first term is input shifted arithmetically right two position.

III. CONVOLUTIONAL FILTERS

A. Filter structure and CSD form

In convolutional filter approach FIR structure is implemented with canonical signed digit form for multiplication operation as said above.

TABLE II
 Quantized filter coefficient for direct implementation

	$H_0^q(z)$		$F_1^q(z)$	
0	0.03515625	0.000010010	-0.0625	0.00010
1	-0.0234375	0.000001100	-0.03125	0.00001
2	-0.1171875	0.001000100	0.4375	0.10010
3	0.376953125	0.011000001	0.78125	0.11001
4	0.8125	0.110100000	0.4375	0.10010
5	0.376953125	0.011000001	-0.03125	0.00001
6	-0.1171875	0.001000100	-0.0625	0.00010
7	-0.0234375	0.000001100		
8	0.03515625	0.000010010		

For canonical signed digit form operation, quantized values need to be expressed as sum or difference of power two, for a multiplierless implementation. The total number of sum or difference of power two terms used must be kept to a minimum in order to achieve hardware efficiency and speed. The challenge is how to allocate a given SPT terms across the co-efficient such that compression performance is maximized.

There is a subset of SPT representation called canonical signed digit (CSD) form; no two adjacent bits are nonzero in CSD form. The canonical form is optimal in terms of how many nonzero digits are required to represent a given number. On an average, a canonical representation uses two third as many nonzero digits as binary representation, so the canonical signed digit form can significantly reduces the no of adders required in hardware.

B. Hardware performance

In relating a hardware implementation of direct form filter, consideration must be given to the hardware architecture. Fig.4 shows the architectural variation considered here.

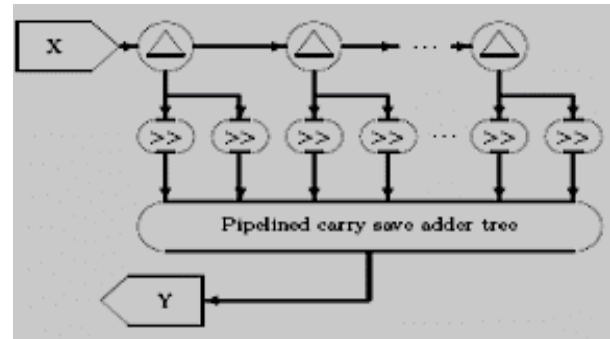

Fig.4 Direct form multiplierless FIR structure used for low pass & high pass filter.

A chain of registers is used to shift the data in and the data is shifted in accordance with filter coefficient before being summed. For example, if one of the filter coefficient were $0.46875 = 2^{-2} - 2^{-5}$ the corresponding data word would go to two shifters and be shifted two and five places respectively before being summed.

TABLE III
 HARDWARE ARCHITECTURE SPECIFICATION.

Specification	RCA TREE	
	$H_0(z)$	$F_1(z)$
SPT terms	21	11
Size (logic cell)	574	307
Latency	5	4
Input format	(8,0)	(8,0)
Output format	(18, -9)	(14, -5)
Clock rate	68.88MHz	102.72 MHz
Power	432.48 mW	347.37 mW

C. Tree operation

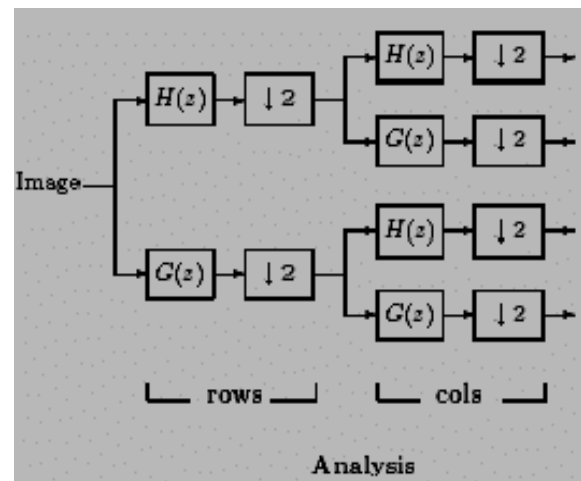

(a) Analysis section two level decomposition

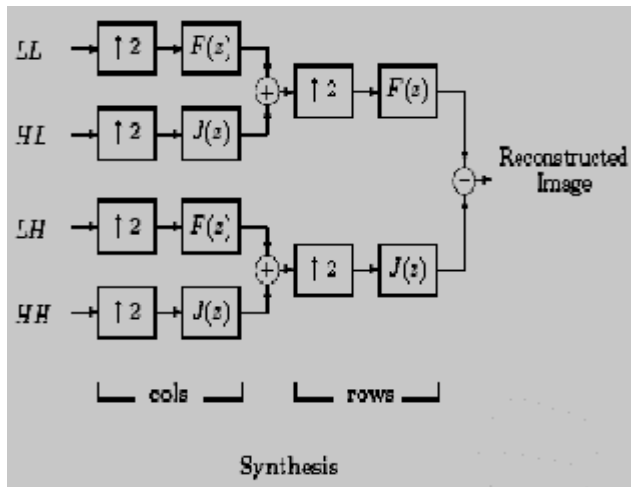

(b) Synthesis section to reconstruct the image

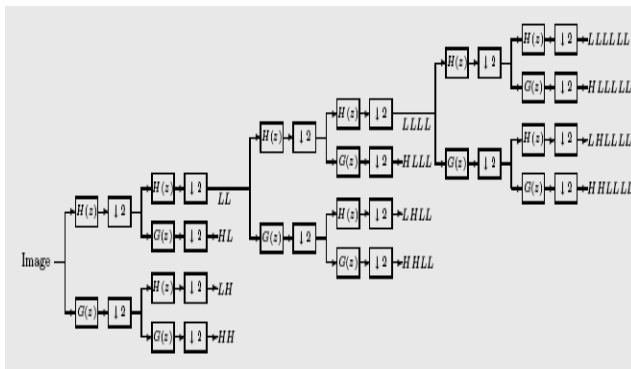

(c) Two level decomposition tree.

Fig. 5. Two Level Decomposition Tree

TABLE IV

COMPARISON OF MULTIPLIER ARCHITECTURE AND MULTIPLICATION ARCHITECTURE.

Architecture	Filter type	Area CCB sizes	Delay
Multiplier	Forw	1801	24.4
	Inv	1787	24.4
Shift-add operation	Forw	634	19.3
	Inv	657	19.7

IV. RESULT

Canonical signed digit operation increase the speed of operation, also reduces the hardware for processing. The results were taken by implementing hardware on a EPF10K200SFC672-3FPGA. Fig.6. has been shown completed filter Bank with analysis and synthesis section with reconstructed input sample

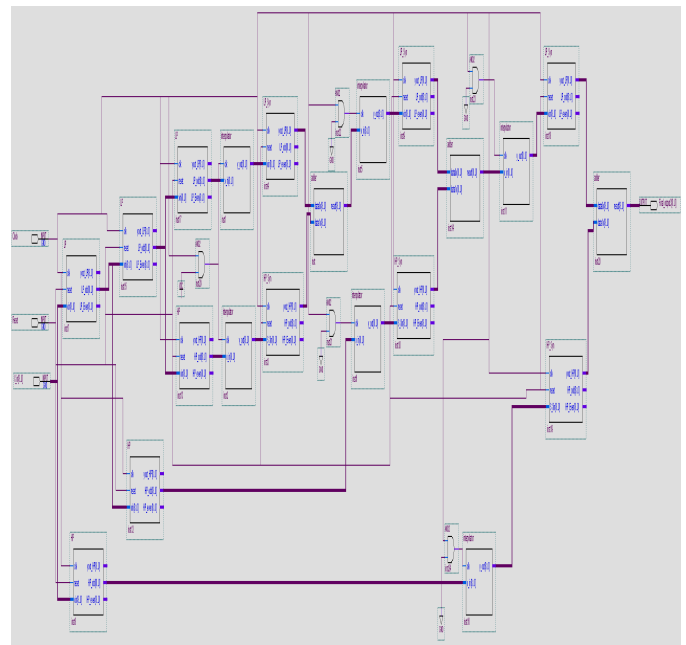

Fig.6. Block diagram of 3-Level Filter Bank with analysis and synthesis section

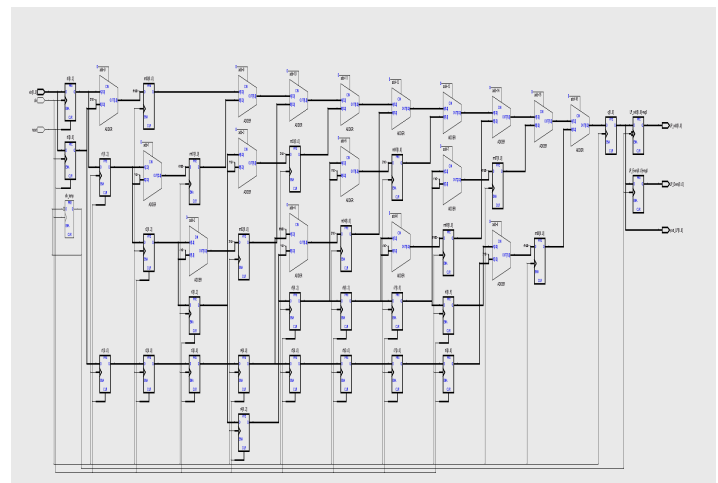

Fig.7. Multiplierless Hardware generated RTL view of FIR filter

Fig.7 has shows the each level's lowpass filter and highpass filter RTL view generated for analysis section with down sampler. Also from mention table IV area read for hardware is also less as compared to multiplier.

Simulation Result:

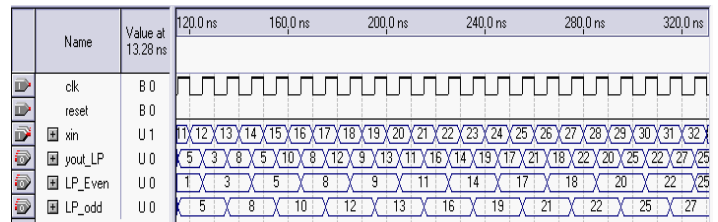

Fig.8. Low pass filter output

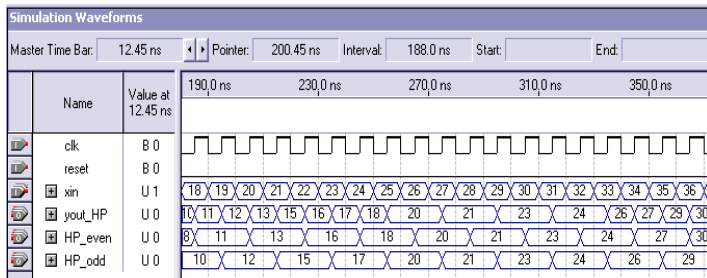

Fig. 9. High Pass Filter Output

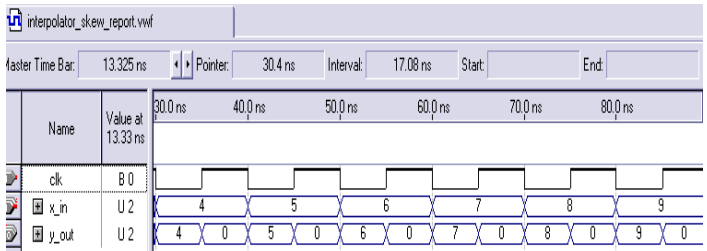

Fig. 10. Interpolator Output

Interpolator has been used in synthesis section to decompress the data at each level by inserting zero after each sample before filtering.

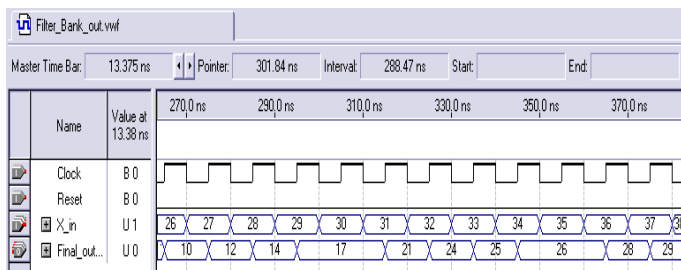

Fig. 11. Filter Bank Output

Multiplierless filter Bank using DWT has shows reconstructed input sample.

V. CONCLUSION

We have approached implementation of discrete wavelet transform both for convolution and lifting based approaches. The multiresolution analysis features of the wavelet transform have been implemented, which makes it suitable for image compression. The multiresolution analysis-based discrete wavelet transform is foundation of the new JPEG2000 standard. Multiplierless filter bank approach is new and became popular in terms of hardware reduction for signal processing. Hardware is found to reduce as compared to lifting architecture.

REFERENCES

- [1] M. Antoninis “Image coding using wavelet Transform” IEEE Transactions on Image processing No1, No 2 April 1992.
- [2] G. Strang and T.N guyen, “Wavelets and filter Banks”, 1st edWellesley. MA Wellesley – Cambridge press 1996.
- [3] “FIR filter design over discrete powers of two co-efficient space” by Y.C.Lim and B.R. Parker IEEE Trans. Acoust. Speech and signal Processing vol. Assp –3/pp 583-59 Jun. 1983.
- [4] “Design of multiplierless, High performance, wavelet filter Banks with Image Compression application”. Kishore A koteri, IEEE transaction on circuit And systems-I regular papers val 51, no.3

march-2004.

- [5] W. Sweldens “ The lifting scheme and construction of second generate wavelets” in SIAMJ math no. 2 vol. 29, -1987.