

A Multi-objective Approach to Implement an Integrated Management System: Quality, Security, Environment

Ahmed Badreddine*

Taieb Ben Romdhane**

Nahla Ben Amor *

Abstract—This paper proposes a partial implementation of an integrated Quality, Security and Environment management system [1] to deal with the definition of an appropriate global management plan. This implementation is based on the multi-objective influence diagrams [12] which are one of the most commonly used graphical decision models for reasoning under uncertainty with multiple objectives.

Keywords: *Integrated management system, Risk management, Multi-objective influence diagram, Bow tie.*

1 Introduction

The evolution of the current industrial context and the increasing of the competition pressure, led the companies to adopt new concepts of management. That's why the implementation and certification of quality (ISO 9001) [5], environmental (ISO 14001) [6] and occupational health and safety (OHSAS 18001) [13] systems have been an important activity for many organizations and have become a widespread phenomenon around the world. The major problem with these three management systems is that they were proposed separately and thus their combination is not an obvious task since they have common and confused procedures. Generally, parallel management systems are used, leading to separate and independent implementations of each system. Such implementations suffer from several weaknesses since they require many duplicate management tasks, such as written procedures, checking, control forms and other paper work suggested by the three standards. Hence, proposing an integrated management system (IMS) including quality, environment and safety management systems also known as QSE management system have drawn the attention of both academics and practitioners. These researches studied the integration of the three systems from various viewpoints, including examining the possibility of integrating, analyzing the potential benefits of it and exploring possible ways and criteria for its success [10][8][20][9].

*LARODEC, Institut Supérieur de Gestion de Tunis, 41 Avenue de la liberté, 2000 Le Bardo, Tunisie. **Institut National des Sciences Appliquées et de la Technologie, Centre Urbain Nord BP 676 - 1080, Tunisie. Email: badreddine.ahmed@hotmail.com, benromdhane.t@planet.tn, nahla.benamor@gmx.fr

Nevertheless, a few studies have developed methodologies and approaches to implement an IMS. Recently, we have proposed a new process based approach to implement an IMS, on the basis of three aspects used as integrated factors namely the *process approach*, the *risk management* and a *global monitoring system* [1]. This approach is composed of three phases: the *Plan* phase, the *Do* phase and the *Check* and the *Act* phases.

This paper proposes an implementation of the most important part of the plan phase, consisting in the definition of an appropriate global management plan QSE. This implementation is based on the multi-objective influence diagrams (MIDs)[12] which are one of the most commonly used graphical decision models for reasoning under uncertainty. More precisely, we propose to map existing *bow ties* which are a very popular and diffused risks analysis tool into a MID, then to evaluate it in order to generate an appropriate global management plan.

The remainder of this paper is organized as follows: Section 2 presents a brief recall on the new process based approach for implementing an IMS. Section 3 proposes a multi-objective approach to define an appropriate global management plan QSE. Indeed, a transformation algorithm from existing *bow ties* into a multi-objective influence diagrams will be proposed.

2 A brief recall on the new process based approach for implementing an IMS

This section presents a brief recall on the new process based approach for implementing an integrated Quality, Security and Environment management system. This approach is based on three integrated factors [1]: *Risk management* to increase the compatibility and the correspondence between the three systems, *Process-based approach* to deal with coordination and the interactions between the activities of a company, *Monitoring System* to ensure the monitoring of the global system and the integration as a continuous improvement of the performance.

The proposed approach is illustrated by figure 1, where the different steps cover the whole PDCA (Plan, Do, Check, Act) scheme. The idea here is to gather these

steps into three phases such that the first one concerns the *Plan* phase, the second, the *Do* phase and the third the *Check* and the *Act* phases. These three phases can be detailed as follows [1]:

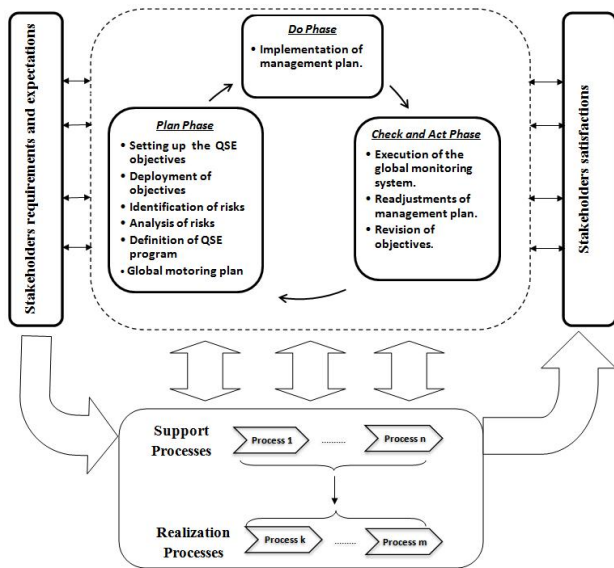

Figure 1: Proposed process-based approach for IMS [1]

- Plan phase:** This phase is composed of six steps: the first consists in setting up all quality, security and environment objectives issued from the requirements and the expectations of stakeholders (i.e. customers, employees, population, environment, etc.). In the second, we will deploy all these objectives in each process. The third step consists in the analysis of each process with respect to the pre-set objectives defined in the second one in order to identify the sources of hazard and possible targets leading to a possible failure to reach up the objectives. In the fourth step, each identified risk has to be analyzed in term of potential consequences in each management area. In the fifth step we have to define a global management plan QSE to implement selected treatments as preventive and corrective actions, in order to reduce levels of risks already identified and to improve the efficiency of the IMS. To this end, we have to consider the interaction between the different management areas, indeed some decisions can be beneficial for some management areas and harmful for others. Finally, the sixth step is devoted to the definition of an appropriate monitoring plan, in order to ensure the well implementation of the global management plan.

- Do phase:** This phase has as input the global management plan QSE and the corresponding global monitoring plan generated from the *plan* phase and

will implement the selected treatments. Note that we have to define the appropriate Scheduling to optimize the resources in order reach up the objectives more efficiently.

- Check and Act phase:** Once the do phase achieved, this phase will finalize the process of integration by the measure of the effectiveness of different decisions and their readjustments via three steps. In the first one, we have to measure all the indicators already defined in order to evaluate the effectiveness of selected treatments and to estimate the degree of achievement of objectives. For this reason, we have to aggregate the indicators of each objective. In the second step, a readjustment of the management plan will be done in order to satisfy unreached objectives. Although, some objectives may not be reached, that is why we should revise some of the initial assigned objectives in order to make their satisfaction possible, in this context we propose the third step (i.e. revision of objectives) in order to contribute to sustainable development.

3 A multi-objective approach for a global management plan QSE

In this section we propose an implementation of the most important part of the *Plan* phase consisting in the definition of an appropriate global management plan QSE. In fact, as indicated in section 2, our idea is to use the risk management as integrating factor and to consider the different interactions between policies, objectives and resources of the quality, security and environment standards. Several approaches for risk evaluation exist, within the most famous ones we can mention, *preliminary risk analysis* (APR), *hazard operability* (HAZOP), *failure mode and effects analysis* (FMEA), and tree-based technique such that *fault tree analysis*, *event tree analysis* and *bow tie analysis*. Unfortunately, these methods are not appropriate to deal with many management areas simultaneously and they are usually limited to technical level. Moreover, since 2003 it is necessary to respect the law 2003-699 [7] relative to the introduction of probability concepts in any risk analysis which is not the case of all these tools. In the literature some researches has been carried out to take into account this law. Most of these researches are based on tree-based techniques which offer a flexible structure to be used with probability concepts. Moreover, several approaches concerning the introduction of probabilistic concepts with risk analysis are particularly focalized on *Bayesian networks* which are a popular tool for representing uncertainty in artificial intelligence [15]. These approaches can be divided into three classes:

- The principle of the first class is to *transform* a risk analysis tool into a Bayesian network. This idea was

first introduced by Bibbio et al. [2] which propose a mapping from fault tree analysis into Bayesian networks. In the same context, léger et al. [11] propose to extend the technical bow tie analysis to a global system, including human beings and organizations.

- The principle of the second class is the *fusion* of a risk analysis tool and a Bayesian network. We can mention in particular the work of Trucco et al. [18] where Bayesian networks are used as an extension of the fault tree in order to introduce the social activity in the evaluation of the latter.
- The third class does not require any risk analysis tools. In fact each identified risk will be directly modeled by a Bayesian network as proposed by Palaniappan [14].

The first problem with these methods is that they deal with a unique management area, so they cannot be applied in the context of a fully integrated management system. Moreover, the fact that these methods are based on Bayesian networks presents a real weakness since this graphical model is not really appropriate to generate optimal decisions. In fact, the power of Bayesian networks consists in their ability in reasoning under uncertainty and not in decision making area. For this reason, several extensions were proposed in order to extend them to the decisional aspect. Thus, our objective is to model a more efficient risk management tool by using an appropriate graphical decisional model. More precisely, we propose to use *influence diagrams* which are an extension of Bayesian networks able to provide optimal solutions while maximizing decision makers utilities. Moreover, given the multi-objective aspect of our problem, we will use *multi-objective influence diagrams* (MIDs) which are a new variant of influence diagrams dedicated to such a problems. Thus our idea is to map existing *bow ties* which are a very popular and diffused risks analysis tool into a MID, then to evaluate it in order to generate an appropriate global management plan QSE. Before detailing our approach we propose a brief recall on bow tie analysis and multi-objective influence diagrams.

3.1 Bow tie method

The bow tie method is a very popular and diffused probabilistic technique developed by shell for dependability modeling and evaluation of large safety-critical systems. The principle of this technique is to build for each identified risk R_i (also called *top event* (TE)) a bow tie representing its whole scenario on the basis of two parts, as shown in figure 2: The first part corresponds to the left part of the scheme which represents a *fault tree* defining all possible causes leading to the (TE). These causes can be classified into two kinds: the first are the initiator events (IE) which are the principal causes of the TE, and the second are the undesired or critical events (IndE

and CE) which are the causes of the IE. The construction of the left part proceeds in top down manner (from TE to IndE and CE). The relationships between events and causes are represented by means of logical AND and OR gates. The second part corresponds to the right part of the scheme which represents an *event tree* to reach all possible consequences of the TE. These consequences can be classified into three kinds: second events (SE) which are the principal consequences of the TE, dangerous effects (DE) which are the dangerous consequences of the SE and finally majors events (ME) of each DE. The construction of the event tree proceeds as the fault tree i.e. in top down manner.

The bow tie also allows to define in the same scheme the *preventive barriers* to limit the occurrence of the TE and the *protective barriers* to reduce the severity of its consequences. In spite its widely use in many organizations, this method remains limited by its technical level and by the graphical presentation of different scenarios without any suggestion about optimal decisions regarding the objectives expected.

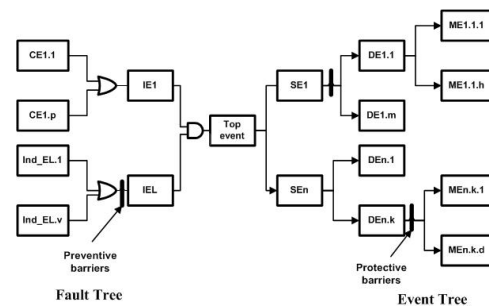

Figure 2: A bow tie analysis model

3.2 Multi-objective influence diagrams

Influence diagrams (IDs), initially proposed by Howard and Matheson [4], are within most commonly used graphical decision models for reasoning under uncertainty. Their success is due their clarity and their simplicity since their topology (chance node, value node and decision node) is easily comprehensible by decision makers. Moreover their evaluation provides the optimal solutions while maximizing the decision makers utilities. Formally, an influence diagram has two components:

1. **Graphical component** (or qualitative component) is a directed acyclic graph (DAG) denoted by $G = (N, A)$ where A is the set of arcs in the graph and N its node set. The node set N is partitioned into subsets C , D and V such that:
 - $C = \{C_1 \dots C_n\}$ is a set of chance nodes which represent relevant uncertain factors for decision problem. Chance nodes are represented by circles.

- $D = \{D_1 \dots D_m\}$ is a set of decision nodes which depict decision options. These nodes should respect a temporal order. Decision nodes are represented by rectangles.
- $V = \{V_1 \dots V_k\}$ is a set of value nodes which represent utilities to be maximized, they are represented by lozenges.

Arcs in A have different meanings according to their targets. We can distinguish *Conditional arcs* (into chance and value nodes), those that have as target chance nodes represent probabilistic dependencies and *Informational arcs* (into decision nodes) which imply time precedence.

Influence diagrams are required to satisfy some constraints to be *regular*, in particular value nodes cannot have children and there is a directed path that contains all of the decision nodes. As a result of this last constraint, influence diagrams will satisfy the *no-forgetting* property in the sense that a decision node and its parents should be parents to all subsequent decision nodes.

2. **Numerical component** (or quantitative component) consists in evaluating different links in the graph. Namely, each conditional arc which has as target a chance node C_i is quantified by a conditional probability distribution of C_i in the context of its parents. Such conditional probabilities should respect the probabilistic normalization constraints. Chance nodes represent uncertain variables characterizing decision problem. Each decision alternative may have several consequences according to uncertain variables. The set of consequences is characterized by a utility function. In IDs, consequences are represented by different combinations of value node's parents. Hence, each value node is quantified by a utility function, denoted by U , in the context of its parents. The definition of the numerical component is in general done by experts and decision makers.

Once the ID constructed it can be used to identify the optimal policy, this can be ensured via evaluation algorithms which allow to generate the best strategy yielding to the highest expected utility. In 1990, Cooper has shown that this problem is NP-hard. Within proposed evaluation algorithms, we can distinguish *direct* methods which operate directly on influence diagrams [16] [17] or *indirect* ones [3] [19] which transform them into a secondary structure (s.t. a Decision tree or a Bayesian network) and then operate on it.

Standard IDs are usually limited to single objectives or a combined one. Recently, they have been extended to deal with multiple objectives decision problems (MIDs) [12] by gathering different objectives in a unique value node. Obviously, to consider such a node, some modifications are

required on the functional and numerical level. The basic modifications required to evaluate a (MIDs) compared to a (IDs) are defined in the:

1. *Chance Node removal*: where two cases have to be considered.

Case A: is performed when no decision nodes have been removed prior to the removal of the current chance node, In this case, the conditional expectation procedure is very similar to that in a single objective influence diagram. So, for each unique combination of alternatives and outcomes of the other influences to the value node, the expectation operation is performed on each outcome of the chance node being removed. The only difference is that the expectation operation is performed on each objective in the vector, instead of on a single objective only.

Case B: is performed when one or more decision nodes have been removed prior to the current chance node. For this case, each possible outcome of the chance node can have associated with it a set of one or more noninferior decision rules. A decision rule is simply defined as a particular decision alternative chosen when a certain outcome of a chance node occurs.

2. *Decision Node Removal*: the required modification is that the simple maximizing operation must be replaced with an operation that can determine the set of noninferior solutions.

Otherwise, the extension to (MIDs) has no effect on the arc reversal and the barren node (a node without a successor) removal transformations.

To evaluate such diagrams Micheal et al. [12] have proposed a direct evaluation algorithm based on arc reversal and node deletion. This algorithm is defined as follows:

1. Make sure that the influence diagram is oriented and regular.
2. Eliminate any barren nodes.
3. If a chance node exists with the value node as its sole successor, remove this chance node with the modified transformation. If any nodes remain in the diagram return to step 3. Otherwise, terminate algorithm
4. If there exists a decision node that is a direct predecessor of the value node such that all other predecessors of the value node are informational predecessors of the decision node, remove this decision node with the modified transformation and eliminate any barren nodes. If any nodes remain in the diagram return to step 3. Otherwise, terminate algorithm.

5. Find a chance i node that is a direct predecessor to the value node such that it has no decision node successors.
6. Find a chance node j that is a direct successor of i such that there is no other directed path between i and j and reverse the arc between i and j . If chance node has any other successors repeat step 6.
7. Remove chance i node with the modified transformation. If any nodes remain in the diagram return to step 3. Otherwise, terminate algorithm.

The final output of this algorithm is the optimal decisions satisfying all the objectives defined in the utility node.

3.3 Transformation of bow ties into a MID

In order to generate the optimal global management plan satisfying all the objectives, we propose a mapping from existing bow ties to build a multi-objective influence diagram. In fact, our idea is to gather all the QSE required objectives in the same value node, then each identified risk and its respective scenario occurrence from initiators to final consequences will represent the chance nodes, and finally the barriers operations considered by the bow tie analysis as preventive and corrective actions will be mapped as decision nodes in order to define the appropriate management plan. Once this building phase achieved, we should quantify the resulted multi-objective influence diagram as explained in subsection 3.2.

To deal with, we propose a transformation procedure (i.e. Algorithm 1) to provide an automatic transformation from the bow ties model to an alternative model (MID) that facilitates the calculation of optimal strategies.

Let $BT_1..BT_n$ the set of bow ties and $O_1..O_k$ the set of objectives. Let R_i be top event of BT_i and F_i be its occurrence. Let IE_i (resp. CE_i , $IndE_i$, SE_i , DE_i , ME_i) be the set of initiator (resp. critical, undesired, second, dangerous, majors) events in BT_i . Let Cq_i (resp. Cs_i , Ce_i) be the consequence on quality (resp. security, environment) in BT_i . Let X_i and Y_i be any set of events in BT_i , then $Ar(X_i, Y_i)$ is a function which returns the set of arcs relative to all links between X_i and Y_i in BT_i . For instance $Ar(IE_i, CE_i)$ is the set of arcs relative to all links between IE_i and CE_i in BT_i . Let $ArCq_i$ (resp. $ArCs_i$, $ArCe_i$) the set of major events which have a possible links to Cq_i (resp. Cs_i , Ce_i) in BT_i . Let $PreB_i$ (resp. $ProB_i$) be the set of *preventive* barriers (resp. *protective*) barriers in BT_i . Let $PE(\cdot)$ (resp. $SE(\cdot)$) be a function which returns the set of *precedent* (res. *successive*) events of any barrier in BT_i . Let D the set of all barriers. Let $ArpB$ the set of additional arcs relative to the links between each element of D to each event. Let ord be the order relative to different decision nodes

relative to existing barriers in $BT_1..BT_n$, this order can be defined by experts. Let $nb(\cdot)$ be a function returning the nb of elements of a given set. Then the following algorithm outlines the major steps of our approach:

Algorithm 1: Transformation of bow ties into a regular MID

Data: $BT_1..BT_n$; $O_1..O_k$; $ArCq_1..ArCq_n$;
 $ArCs_1..ArCs_n$; $ArCe_1..ArCe_n$;
 $ArpB$; ord

Result: MID

begin

Building phase:

- $C \leftarrow \emptyset$, $D \leftarrow \emptyset$, $V \leftarrow \emptyset$, $A \leftarrow \emptyset$
- Gather all the QSE objectives O_i ($i=1..k$) in the same value node V_{QSE}
- $V \leftarrow V_{QSE}$

for $i \leftarrow 1..n$ **do**

 % Create R_i and F_i and connect them

$C \leftarrow C \cup R_i \cup F_i$

$A \leftarrow A \cup (R_i \rightarrow V_{QSE}) \cup (F_i \rightarrow R_i)$

 % Create all the events and connect them

$C \leftarrow C \cup IE_i \cup CE_i \cup IndE_i \cup SE_i \cup DE_i \cup ME_i$

$\forall IE_{ij} \in IE_i, A \leftarrow A \cup (IE_{ij} \rightarrow F_i)$

$\forall SE_{ij} \in SE_i, A \leftarrow A \cup (F_i \rightarrow SE_{ij})$

$A \leftarrow A \cup Ar(IE_i, CE_i) \cup Ar(IE_i, IndE_i) \cup$

$Ar(SE_i, DE_i) \cup Ar(DE_i, ME_i)$

 % Create Cq_i , Cs_i , Ce_i and connecte them

$C \leftarrow C \cup Cq_i \cup Cs_i \cup Ce_i$,

$A \leftarrow A \cup (Cq_i \rightarrow R_i) \cup (Cs_i \rightarrow R_i) \cup (Ce_i \rightarrow R_i)$

$\forall ArCq_{ij} \in ArCq_i, A \leftarrow A \cup (ArCq_{ij} \rightarrow Cq_i)$

$\forall ArCs_{ij} \in ArCs_i, A \leftarrow A \cup (ArCs_{ij} \rightarrow Cs_i)$

$\forall ArCe_{ij} \in ArCe_i, A \leftarrow A \cup (ArCe_{ij} \rightarrow Ce_i)$

 % Handel barriers

$D \leftarrow D \cup PreB_i \cup ProB_i$

$\forall PreB_{ij} \in PreB_i, \forall ProB_{ij} \in ProB_i$,

$A \leftarrow A \cup (PreB_{ij} \rightarrow PE(PreB_{ij})) \cup (ProB_{ij} \rightarrow$

$SE(ProB_{ij}))$

 % Additional links

$A \leftarrow A \cup ArpB$

 % Connect decision nodes while respecting the precedence order.

$n_1 \leftarrow nb(D)$

for $k \leftarrow 1..(n_1 - 1)$ **do**

for $l \leftarrow (k + 1)..n_1$ **do**

$A \leftarrow A \cup (D_{ord(k)} \rightarrow D_{ord(l)})$

Quantification phase: Assign the numerical values for each node in the MID.

end

It is important to note that this algorithm provide a regular influence diagram satisfying the no-forgetting property.

3.4 Illustrative example

This section proposes an illustrative example of our approach. This example is relative to the decision problem faced during the definition of a global management plan for a *gas bottle manufacturer* which is certified in quality, security and environment management systems. For the sake of simplicity, we will only consider three objectives i.e. *Satisfy customers*(Oq), *Minimize the environmental waste*(Oe) and *Increasing safety staff*(Os), respectively

relative to quality, security and environment management systems. We will also consider a unique Bow tie (BT_1) relative to a *Protective device broken*(R_1) which can take three states high, medium, low. The first step is to proceed to the bow tie analysis of the identified risk (R_1) considered as the top event. As shown in figure 3, we consider two initiator events (i.e. *Bad quality of assembly*(BQA) and *Problems related to the maintenance*(PRM)), a second event i.e. *Gas outburst*(GO), a dangerous effect i.e. *Explosion risk*(ER), three major events (i.e. *Injured staff*(IS), *Destruction of products*(DP) and *Environmental pollution*(EP)), a preventive barrier i.e. *Training staff*(TS) to reduce the occurrence of the (TE) due to the quality of assembly, and a protective barrier to reduce the risk of explosion by *Setting up personnel protective equipments*(PPE).

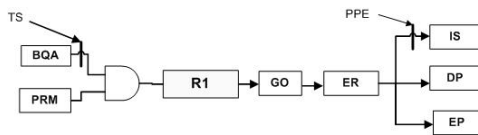

Figure 3: A bow tie analysis of R1

Once the bow tie analysis achieved, we will apply our transformation procedure (i.e. Algorithm 1). the required data are: BT_1 ; O_q, O_s, O_e ; $ArCq_1 = \{DP\}$ since destruction of products has consequences on quality; $ArCs_1 = \{IS\}$ since injured staff has consequences on security, $ArCe_1 = \{EP\}$ since environmental pollution has consequences on the environment. The additional arcs defined in $ArpB_1$ are (Ts, PRM) since successive trainings can increase equipments failures rates; (Ts, C_{s1}) since successive trainings can increase increases the injury rates, (PPE, C_{e1}) since some protection equipments are considered as pollutant for the environment (e.g. extinguisher). Regarding the precedence order between the two decision nodes, we suppose that *Setting up personnel protective equipments* precedes *Training staff*, therefore $ord_1 = \{1,2\}$.

First our algorithm gather all the Q,S,E objectives in the same value node V_{QSE} , then it creates the chance node R_1 and F_1 . After, it connects R_1 to V_{QSE} and F_1 to R_1 . Next, it creates BQA, PRM, GO, ER, IS, DP and EP chances nodes, once created it connects first BQA and PRM to F_1 , then F_1 to GO, and finally it connects GO to ER, and ER to (IS, DP and EP). After, it creates three chance nodes C_{q1}, C_{s1}, C_{e1} , once created it connects them to R_1 , then it connects DE to C_{q1} , IS to C_{s1} and EP to C_{e1} . After that, the algorithm creates the two decision nodes TS, PPE, and connects TS to BQA, and PPE to IS. Then, the algorithm proceeds with the additional links and connects TS to PRM, TS to C_{s1} and PPE to C_{e1} . And finally, it connects TS to PPE in order to respect the precedence order.

The *building phase* generates the multi-objective influence diagram MID illustrated by figure 4 where $C = \{R_1, C_q, C_s, C_e, F, BQA, PRM, GO, ER, DP, IS, EP\}$, $D = \{TS, PPP\}$ and $V = \{V_{QSE}\}$.

Then, we should proceed to the *quantification phase*. For the lack of space we cannot give numerical data here. Once the transformation achieved, we can apply the evaluation algorithm proposed by [12] and presented in subsection 3.2. The final output of this algorithm is the optimal decisions satisfying all the objectives defined, which represent the global management plan QSE. For our illustrative example the final output is the one given by table 1, this means that the optimal decision is not to *train the staff* and to set up the *personal protective equipments* since it is the unique non-inferior solution regarding the three objectives (i.e. O1, O2, O3).

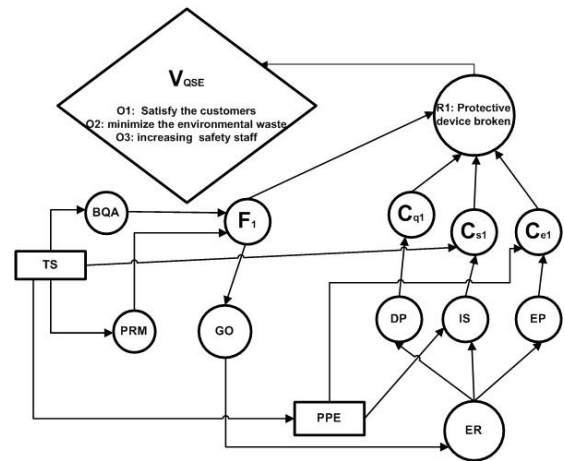

Figure 4: A multi-objective influence diagram of a gas bottle manufacturer

Table 1: Final numerical value results

O1	O2	O3	Training staff	Personal protective equipments
5.52	5.01	4.02	Yes	Yes
4.48	5.5	4	Yes	No
5.58	5.53	4.83	No	Yes
4.33	3.58	2.46	No	No

4 Conclusion

This paper proposes a partial implementation of the new process based approach for integrating Quality, Security and Environment management systems [1]. This implementation concerns the most important part of the plan phase consisting in the definition of the appropriate global management plan QSE. This implementation is based on the transformation of existing bow ties into a multi-objective influence diagram. This choice was motivated by the fact that bow ties are very popular and diffused risk analysis tools allowing to define in the same

scheme the whole scenario from initiators events to finale consequences. Moreover, it defines all the possible actions and decisions as preventive and corrective barriers to reduce the occurrence and the severity of each risk identified. Also the multi-objective influence diagram are one of the most appropriate graphical decision models for reasoning under uncertainty in addition to the fact that they allow the manipulation of different objectives which fits well with our problem since we deal with the three standard QSE. To obtain the optimal and appropriate global management plan QSE, we have proposed a transformation procedure (i.e. Algorithm 1) to provide an automatic transformation from the bow ties model to an alternative model (MID) that facilitates the calculation of optimal strategies. This implementation will directly affect the remaining parts of our integration system since it will provide the global management plan QSE, which should be executed in the Do phase. As a future work we propose to implement a whole decision support system including additional tools in order to implement all steps of integration approach.

References

- [1] Badreddine, A., Ben Romdhane, T., Ben Amor, N., "A New Process-Based Approach for Implementing an Integrated Management System: Quality, Security, Environment," *Proc. The 2009 International Conference on Industrial Engineering, IMECS 2009*, Hong Kong, March 2009.
- [2] Bobbio A., Portinale L., Minichino M., Ciancamerli E., "Improving the analysis of dependable systems by mapping fault trees into Bayesian networks," *Reliability Engineering and System Safety*, N71, pp. 249-260, 2001.
- [3] Cooper, G.F., "A method for using belief networks as influence diagrams," *Fourth Workshop on Uncertainty in Artificial Intelligence*, pp. 5563, 1988.
- [4] Howard R. A., Matheson J. E., "Influence diagrams. The Principles and Applications of Decision Analysis," N2, pp. 719762, 1984.
- [5] ISO 9001:2008, *Quality management system. Requirements*, ISO, 2008.
- [6] ISO 14001:2004, *Environmental management system. Requirements with guidance for use*, ISO, 2004.
- [7] J0 175 ., "Law n 2003-699 concerning the prevention of technological and natural risks, and to the repair of damage," *Official Journal of July 30*, 2003.
- [8] Jorgensen, TH., Remmen, A., Mellado, MD., "Integrated Management Systems-three different levels of integration," *Journal of Cleaner Production*, N14, pp. 713-722, 2006.
- [9] Jorgensen, TH., "Towards more sustainable management systems: Through life cycle management and integration," *Journal of cleaner production*, N16, pp. 1071-1080, 2008.
- [10] Labodova, A., "Implementing integrated management systems using a risk analysis based approach," *Journal of Cleaner Production*, V12, N6, pp. 571-580, 2004.
- [11] Léger A., Duval C., Weber P., Levrat E., Farret R., "Bayesian network modelling the risk analysis of complex socio technical systems," *4th Workshop on Advanced Control and Diagnosis*, Nancy-France, 2006.
- [12] Micheal D., Yacov Y.H., "Influence diagrams with multiple objectives and tradeoff analysis," *IEEE transactions on systems, man and cybernetics*, N34, pp. 293-304, 2004.
- [13] OHSAS 18001:2000, *Occupational health and safety management systems-specification*, BSI: British standard institution, 2007.
- [14] Palaniappan R., "Bayesian networks: Application in safety instrumentation and risk reduction," *ISA Transactions*, N46, pp. 255-259, 2007.
- [15] Pearl J., *Probabilistic reasoning in intelligent systems*, Morgan Kaufmann, Los Altos, CA, 1989.
- [16] Shachter, R.D., "Evaluating influence diagrams," *Operation Research*, N34, pp. 871882, 1986.
- [17] Tatman, J.A., Shachter, R.D., "Dynamic programming and influence diagrams," *IEEE Transactions on Systems, Man and Cybernetics*, N20, pp. 365379, 1990.
- [18] Trucco P., Cagno E., Ruggeri F., Grande O., "A Bayesian Belief Network modelling of organisational factors in risk analysis: A case study in maritime transportation," *Reliability Engineering and System Safety*, N93, pp. 845-856, 2008.
- [19] Xiang, Y., Ye, C., "A simple method to evaluate influence diagrams," *The Third International Conference on Cognitive Science*, 2001.
- [20] Zeng, S.X., Shi, J.J., Lou, G.X., "A synergetic model for implementing an integrated management system: an empirical study in China," *Journal of Cleaner Production*, N15, pp. 1760-1767, 2007.