

Occupancy Controlled Lighting System for Smart Buildings

Aderemi A. Atayero, Victor Ademu-Eteh, Segun I. Popoola, Temitope O. Takpor, and Joke A. Badejo

Abstract— Efficient utilization of the limited available energy in developing countries is a practical solution to the present challenges facing the power sector in the region. Automation of lighting systems in both residential and industrial buildings is one of the strategies for energy efficiency towards a sustainable economic development. In this paper, the authors developed an intelligent lighting system using occupancy control. The prototype consists of an Arduino uno microcontroller, Infrared module, Liquid Crystal Display (LCD), relay, buzzer, and a light bulb. The infrared module senses human presence in a room and transmits a corresponding electrical signal to the Arduino. The relay was connected to the Arduino to act as the control unit. The programmable microcontroller was also used to keep track of the number of people in the room while the information is displayed on the LCD. The system achieved a significant energy saving by switching ON the light bulb only when it is really needed. A large-scale implementation of this smart application in residential and office buildings will encourage energy efficiency, making electrical energy available for other areas which are yet to be connected to the power grid.

Index Terms—Internet of Things; smart lighting system; Infrared sensor; arduino; energy efficiency

I. INTRODUCTION

THE supply of electrical energy in most developing countries is relatively low when compared to the high demand for the essential commodity [1]. For instance, the power generating capacity required to adequately meet the load demand in Nigeria is above 140,000 MW but the currently installed capacity is only about 8039 MW [2]. Efficient utilization of the limited available energy in developing countries will help in handling the present challenges facing the power sector in the region. Automation of lighting systems in both residential and industrial buildings is one of the strategies for energy efficiency towards a sustainable economic development. Energy savings achieved from smart lighting control will reduce costs and eliminate the need for the commissioning of additional power stations. On the other hand, energy saved can be made available to areas which are yet to be connected to the power grid. In addition to these benefits, energy efficiency also encourages environmental

sustainability.

The contribution of lighting to the total energy expended globally is approximately 20% [4]. 18% of the total energy consumed in commercial and office buildings are expended on lighting [5]. The range of energy consumed in office building per annum is between 100 and 1000 kilowatt-hour per square meter [6]. The value depend on several factors which also include the period of use. Therefore, savings of energy consumed by lighting when it is not needed will reduce the annual consumption rate drastically.

Recent development in solid state Light Emitting Diode (LED) technology is a great opportunity for the rapid penetration and adoption of smart lighting systems [3]. LED lighting is known for its energy efficiency and long lifespan. It can be easily controlled, unlike the conventional halogen and fluorescent lamps. Occupancy sensing obtains feedback from electronic sensors which are nitrated into an embedded system [7, 8]. Occupancy control-based smart lighting is an energy-efficient method for lighting control. In this approach, the artificial lighting of the indoor environment depends on the number of people in the room. A sensor is deployed to detect human presence. This information is then used to actuate the smart lighting system. The main advantage of this approach is that energy is consumed only when it is needed, thereby reducing cost and making energy available to others. It is also effective as it requires no human intervention to operate.

In this paper, the authors developed an intelligent lighting system using occupancy control. The prototype consists of an Arduino microcontroller, Infrared module, Liquid Crystal Display (LCD), relay, buzzer, and a light bulb. The infrared module senses human presence in a room and transmits a corresponding electrical signal to the Arduino. The relay was connected to the Arduino to act as the control unit. The programmable microcontroller was also used to keep track of the number of people in the room while the information is displayed on the LCD.

The remaining of this paper is organized as followed: Section II states the materials used and explains the methodology employed; Section III discusses the design implementation and testing procedure of the prototype; and Section IV concludes the paper.

II. MATERIALS AND METHOD

The smart lighting system consists of the sensing unit, the controlling unit, the display unit, and the relay driving unit. These units interface with one another to achieve the objectives of this work.

In this work, a 9-volt DC power is needed to efficiently operate the smart lighting system. The transformer used is a

Manuscript received May 15, 2017; revised August 01, 2017.

This work was supported in part by the Center for Research, Innovation, and Discovery (CU-CRID) of Covenant University, Ota, Nigeria.

A. A. Atayero, V. Ademu-Eteh, S. I. Popoola, T. O. Takpor, and J. A. Badejo are with the Department of Electrical and Information Engineering, Covenant University, Ota, Nigeria. (Corresponding Author: +2348058659008; +2347038049956; e-mail: segunpopoola15@gmail.com; segun.popoola@stu.cu.edu.ng).

center-tapped step down transformer. This is meant to step the mains voltage to produce two sets of 12-volt AC output that can be harnessed into 24-volt AC. A 220-volt AC mains voltage was supplied to the transformer. A switch and a fuse were placed on the ‘live’ wire to protect against over-voltage. The AC output of voltage transformation was converted into DC using the full-wave rectification process. Due to the pulsating nature of the DC output, the pulsating voltage was filtered to eliminate AC ripples. An electrolytic-type capacitor was used to achieve a smooth DC output. Also, a fixed positive linear voltage regulator was used to obtain a steady output of 15-volt DC output.

The prototype smart lighting system comprises of the Arduino microcontroller, the Infrared module, the Liquid Crystal Display (LCD), the relay, the buzzer, and a light bulb. The lighting system is controlled automatically based on room occupancy. The relay was connected to the Arduino to act as the control unit. The infrared module senses human presence in a room and transmits a corresponding electrical signal to the Arduino. The infrared module is sensitive to the direction of incoming object. The programmable microcontroller was also used to keep track of the number of people in the room while the information is displayed on the LCD. When the limit of people that can access the room is reached, the buzzer connected to the Arduino is activated.

The Arduino coordinates the activities of the infrared module, the relay, and the LCD. This allows the relay to respond adequately to the signal sent by the infrared module. The infrared sensor module has a pair of infrared transmitter and the receiver tube. The infrared emits electrical signals at a certain frequency. The infra-red module is shown in Figure 1. When an obstacle is encountered, it acts as a reflecting surface, and the signal is reflected back to the receiver tube. Based on comparator circuit processing, a digital signal output is produced. The effective distance range is between 2 cm and 80 cm. The detection range of the sensor can be adjusted by the potentiometer with little interference. A 16 x 2 LCD unit was used.

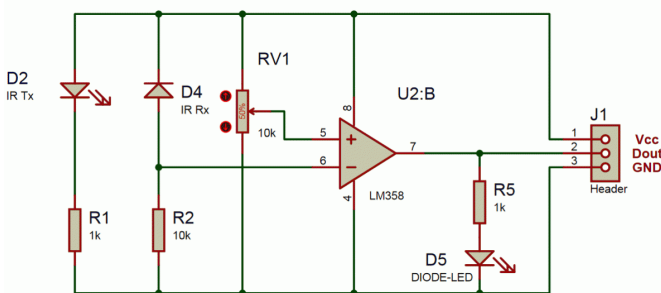

Figure 1: Infrared Module Circuit

The sensing unit is made up of the IR sensor, the potentiometer, the comparator (Op-Amp), and the Light Emitting Diodes (LEDs). The potentiometer was used to set the reference voltage at the comparator while the IR sensor senses the object or person that is in the detection zone, providing a change in voltage at the second terminal of the comparator. The comparator then compares both voltages and generates a digital signal as output. In this work, two

comparators were used as the sensors while LM358 was used as a comparator.

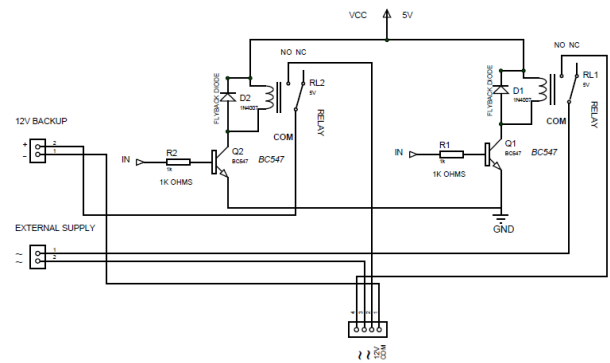

Figure 2: Transistor Relay Circuit

Arduino uno microcontroller forms the heart of the controlling unit. It coordinates the activities of the other units of the smart lighting system. The outputs of the comparators were connected to the digital pins 14 and 19. Arduino reads the input signal and sends corresponding commands to the relay driving circuit which controls the light bulb. The transistor relay circuit is shown in Figure 2. Figure 3 represents a comprehensive methodology of the design of the smart lighting system.

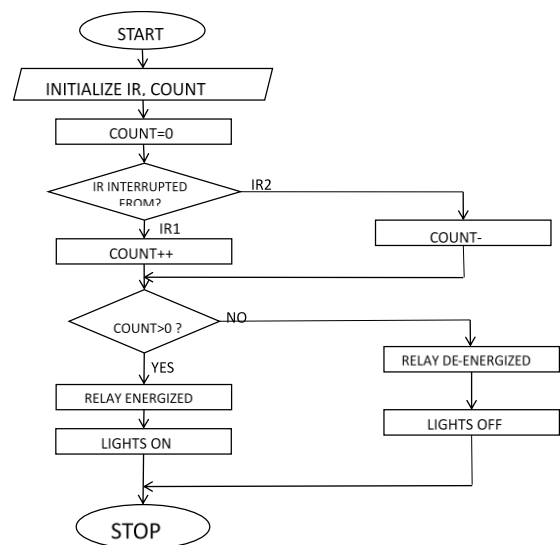

Figure 3: Flow Chart of Smart Lighting System

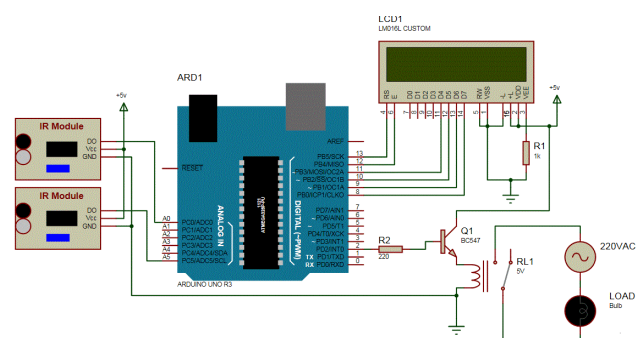

Figure 4: System Design Circuit

The Arduino microcontroller is powered through the DC input jack using 9-volt DC supply obtained from the 7809 voltage regulator. The infrared module was powered by the 5-volt output of the Arduino circuit. The LCD unit is also powered by the Arduino circuit.

III. DESIGN IMPLEMENTATION AND TESTING

The design of the smart lighting system was successfully implemented on Vero boards. Various components of the system were carefully soldered and appropriate tests were conducted to ensure proper functionalities of each unit.

A 9-volt DC power is supplied to the Arduino. The power supply was connected to the Arduino through a 7809 voltage regulator. The Arduino was programmed using the Arduino Integrated Development Environment (IDE). Also, the infrared modules were connected to the Arduino using connecting wires. The digital output pins of the infrared modules were connected to pins 6 and 7 of the Arduino while the V_{CC} was connected to the 5-volt pin of the Arduino.

The buzzer was soldered to the Vero board with the pins connected to the GND and pin 14 of the Arduino. The relay unit was soldered on a small strip Vero board where a BC547 transistor was used as the switching element and the input signal pin was connected to pin 2 of the Arduino. The LCD was connected to the Arduino using the headers pins and wires. The internal connections of the complete system is shown in Figure 5.

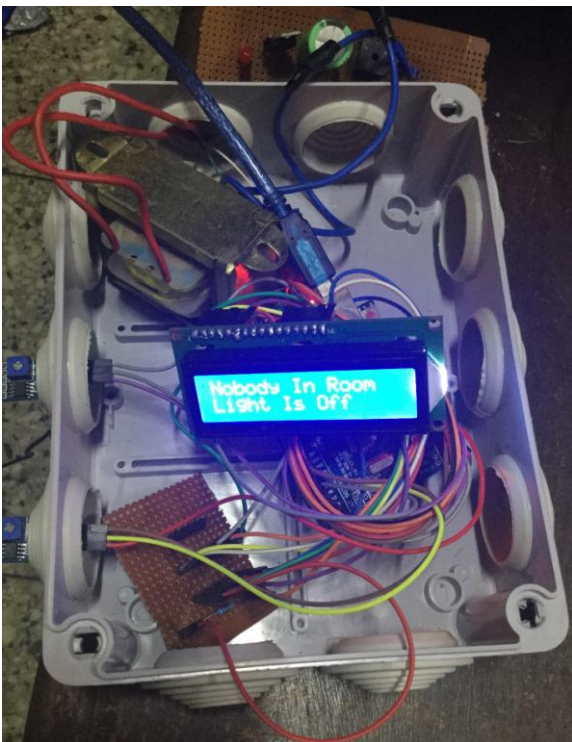

Figure 5: Internal Circuitry of the Smart Lighting System

The system was tested for workability. The output voltage from the power supply was measured to be 8.5 volts. Some kind of electromagnetic interference was experienced in the LCD display due to the interaction between the AC load and the DC relay. This affects the efficiency of the LCD display unit. The LCD was powered

from a separate DC source to mitigate this adverse effect.

At the start of the system, the count is initialized to zero and the LCD displays “Nobody in room, light is OFF”. But when an object crosses the line of sight of the ‘in’ infrared module, the count is incremented by one and a delay is implemented to allow the person pass before the next count. On the other hand, as soon as an object crosses the line of sight of the ‘out’ infrared module, the count is decremented by one and the delay is implemented. Meanwhile, the count is consistently displayed on the LCD. At a count of 1 and above, the system automatically switches ON the light. The room is considered to be full when a count of 10 is reached, and the system displays “Room is full”.

The smart lighting system was well packaged in a plastic enclosure with the LCD on top, as shown in Figure 6, for ease of access. Also, power cables were connected using terminal blocks.



Figure 6: Final System Product

IV. CONCLUSION

This work has demonstrated that significant amount of energy can be saved by automating the control of the lighting systems at homes and offices. The prototype system achieved a significant energy saving by switching ON the light bulb only when it is really needed.

In future work, we plan to design and implement an intelligent lighting system using wireless networks of Internet of Things (IoT)-enabled sensors. The programmability of the IoT devices will allow device-to-device communication over the Internet. By this, the lighting system may be flexibly adapted and reconfigured to specific requirements of different use cases. A large-scale implementation of this smart application in residential and office buildings will encourage energy efficiency, making electrical energy available for other areas which are yet to be connected to the power grid.

ACKNOWLEDGMENT

The authors wish to appreciate the Center for Research,

Innovation, and Discovery (CU-CRID) of Covenant University, Ota, Nigeria, for the partial funding of this research.

REFERENCES

- [1] S. O. Oyedepo, Towards achieving energy for sustainable development in Nigeria, *Renewable and Sustainable Energy Reviews*, Volume 34, June 2014, Pages 255-272, ISSN 1364-0321, <http://dx.doi.org/10.1016/j.rser.2014.03.019>.
- [2] S.O. Oyedepo, R.O. Fagbenle. A study of implementation of preventive maintenance programme in Nigeria power industry—Egbin Thermal Power Plant, case study. *Energy Power Eng*, 3 (2011), pp. 207– 220.
- [3] C. Branas, F.J. Azcondo, J.M. Alonso. Solid-state lighting: a system review. *IEEE Ind. Electron. Mag.* (2013), pp. 6– 14.
- [4] C. Atici, T. Ozcelebi, J. Lukkien. Exploring user-centered intelligent road lighting design: a road map and future research directions. *IEEE Trans. Consum. Electron.*, 57 (2) (2011), pp. 788–793.
- [5] U. D. of Energy. Solid-State Lighting Research and Development Multi-Year Program Plan, Tech. rep (2013).
- [6] M. Santamouris, E. Dascalaki. Passive retrofitting of office buildings to improve their energy performance and indoor environment: the office project. *Build. Environ.*, 37 (6) (2002), pp. 575– 578.
- [7] J. Cooley, D. Vickery, A.-T. Avestruz, A. Englehart, J. Paris, S. Leeb. Solid-state lamp with integral occupancy sensor. *Applied Power Electronics Conference and Exposition (APEC)*, 2010 Twenty-Fifth Annual IEEE (2010), pp. 2305– 2313.
- [8] Y.K. Tan, T.P. Huynh, Z. Wang. Smart personal sensor network control for energy saving in dc grid powered led lighting system. *IEEE Trans. Smart Grid*, 4 (2) (2013), pp. 669– 676.