

Fixed Structure Robust Loop Shaping Controller for a Buck-Boost Converter using Genetic Algorithm

Somyot Kaitwanidvilai, Piyapong Olanthichachat and Manukid Parnichkun

Abstract— Robust controller designed by H_∞ loop shaping is complicated and its order is much higher than that of the plant. It is not easy to implement this controller in practical engineering applications. To overcome this problem, we propose an algorithm, GA based fixed-structure H_∞ loop shaping control, to design a robust controller. Genetic algorithm is used to solve the H_∞ loop shaping design problem under a structure specified controller. The performance and robustness of the proposed controller are investigated in a buck-boost converter in comparison with the controller designed by conventional H_∞ loop shaping method. Results of simulation demonstrate the advantages of simple structure and robustness against plant perturbations and disturbances of the proposed controller. Experiments are performed to verify the effectiveness of the proposed technique.

Index Terms— H_∞ loop shaping , genetic algorithm , buck boost converter

I. INTRODUCTION

DC-DC converters have been widely used in computer hardware and industrial applications. Controlling of these converters is a challenging field because of their intrinsic nature of nonlinear, time-variant systems [1]. In previous research works, the linear models of these converters were derived by using linearization method [2-3]. Some linear control techniques were applied to these converters based on the linear models [1, 4-5]. NAIM, R., *et al.* [4], applied the H_∞ control to a boost converter. Three controllers; voltage mode, feed-forward and current mode control were investigated and compared the performance. G.C. Ioannidis and S.N. Manias [5] applied the H_∞ loop shaping control schemes for a buck converter. In their paper, the μ -analysis was used to examine the robust features of the designed controllers. Simone Buso [1] adopted the robust μ -synthesis to design a robust voltage controller for a buck-boost converter with current mode control. The parameter variations in the converter's transfer function were described in term of perturbations of linear fraction transformations (LFT) class.

In DC to DC converter, normally, the controller is designed by using analog circuit. Although the higher control

techniques mentioned above are powerful techniques for designing the high performance and robust controller; however, the structure of these controllers is complicated with a high order. It is not easy to implement these controllers in the converters. Nevertheless, the design of analog circuit for these controllers is not feasible. To overcome this problem, fixed-structure controller is investigated. Fixed-structure robust controllers have become an interesting area of research because of their simple structure and acceptable controller order. However, the design of this controller by using the analytical method remains difficult. To simplify this problem, the searching algorithms such as genetic algorithm, particle swarm optimization technique, gradient method, etc., can be employed.

Several approaches to design a robust control for structure specified controller were proposed in [6-8]. In [6], a robust H_∞ optimal control problem with structure specified controller was solved by using genetic algorithm (GA). As concluded in [6], genetic algorithm is a simple and efficient tool to design a structure specified H_∞ optimal controller. Bor-Sen.Chen. *et al.* [7], proposed a PID design algorithm for mixed H_2/H_∞ control. In their paper, PID controller parameters were tuned in the stability domain to achieve mixed H_2/H_∞ optimal control. A similar work was proposed in [8] by using the intelligent genetic algorithm to solve the mixed H_2/H_∞ optimal control problem. The techniques in [6-8] are based on the concept of H_∞ optimal control which two appropriate weights for both the uncertainty of the model and the performance are essentially chosen. A difficulty with the H_∞ optimal control approach is that the appropriate selection of close-loop objectives and weights is not straightforward. In robust control, H_∞ loop shaping which is a simple and efficient technique for designing a robust controller can be alternatively used to design the robust controller for the system. Uncertainties in this approach are modeled as normalized co-prime factors; this uncertainty model does not represent actual physical uncertainty, which usually is unknown in real problems. This technique requires only two specified weights, pre-compensator and post-compensator, for shaping the nominal plant so that the desired open loop shape is achieved. Fortunately, the selection of such weights is based on the concept of classical loop shaping which is a well known technique in controller design. By the reasons mentioned above, this technique is simpler and more intuitive than other robust control techniques. However, the controller designed by H_∞ loop shaping is still complicated and has high order. To overcome this problem, in this paper, we propose a fixed-structure H_∞ loop shaping control to design a robust controller for a buck boost converter. In the proposed technique, the controller structure is firstly specified and the genetic algorithm is then

Manuscript received January 31, 2008. This work was supported in part by Faculty of Engineering, King Mongkut's Institute of Technology Ladkrabang, Bangkok, Thailand.

Piyapong and Somyot are with the Department of Electrical Engineering, Faculty of Engineering, King Mongkut's Institute of Technology Ladkrabang, Bangkok 10520, Thailand. Email : kksomyot@kmitd.ac.th
Manukid is with the School of Engineering and Technology, Asian Institute of Technology, P.O. Box 4, Klong Luang, Pathumthani 12120, Thailand.

used to evaluate the control's parameters. Simulation and experimental results show the advantages of simple structure, lower order and robustness of the proposed controller.

The remainder of this paper is organized as follows. Converter dynamics are described in section II. H_∞ loop shaping and the proposed technique are discussed in section III. Section IV demonstrates the design example and results. Finally, section V concludes the paper with some final remarks.

II. CONVERTER MODELING

A typical circuit of buck-boost converter with current mode control is shown in Fig. 1. The dynamic model of this converter from the current reference (i_r) to output voltage (u_o) is given by [2-3]

$$\frac{du_o}{di_r} = R_L \frac{V_i}{V_i + 2V_o} \frac{(1 - \frac{s \cdot L}{R_L} \cdot \frac{V_o}{V_i} \cdot \frac{V_o + V_i}{V_o})}{(1 + s \cdot C \cdot R_L \cdot \frac{V_o + V_i}{2V_o + V_i})} \quad (1)$$

Where R_L is the nominal load resistant, V_o is the nominal output voltage, V_i is the nominal input voltage, L is the inductance of an inductor used in the circuit, C is the capacitance, f_{sw} is the switching frequency.

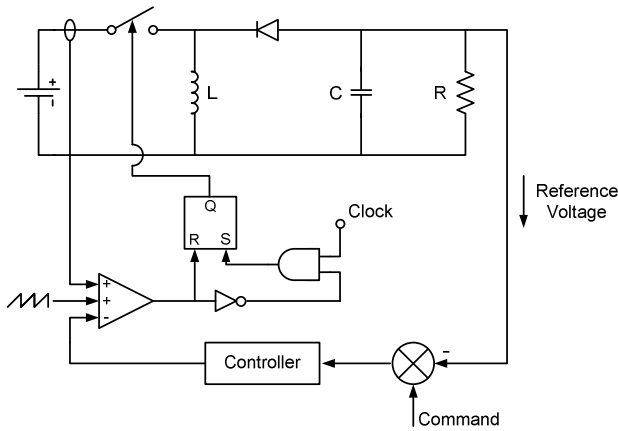

Fig. 1. Buck boost converter with current mode control.

The accuracy of this model has been proved to be accepted, at least in frequency of interest in this application [2-3].

III. H_∞ LOOP SHAPING CONTROL AND PROPOSED TECHNIQUE

This section illustrates the concepts of the standard H_∞ loop shaping control and the proposed technique.

A. Standard H_∞ Loop Shaping

H_∞ loop shaping control [9] is an efficient method to design a robust controller. This approach requires only a desired open loop shape in frequency domain. Two weighting functions, W_1 (pre-compensator) and W_2 (post-compensator), are specified to shape the original plant G_o . In this approach, the shaped plant is formulated as normalized coprime factor, which separates the plant G_s into normalized nominator N_s

and denominator M_s factors. Fig. 2 shows the coprime perturbed plant and robust stabilization used in this approach.

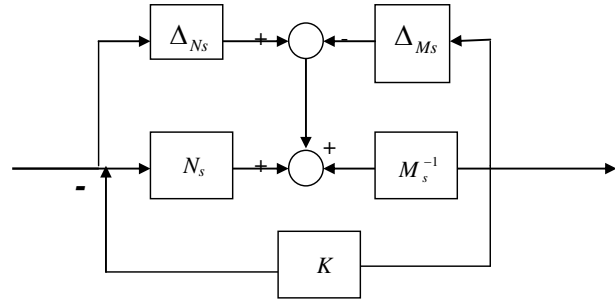

Fig. 2. Co-prime factor robust stabilization problem.

If the shaped plant $G_s = W_2 G_o W_1 = N_s M_s^{-1}$, then a perturbed plant is written as [9]

$$G_\Delta = (N_s + \Delta_{N_s})(M_s + \Delta_{M_s})^{-1} \quad (2)$$

Where Δ_{N_s} and Δ_{M_s} are stable, unknown representing the uncertainty satisfying $\|\Delta_{N_s}, \Delta_{M_s}\|_\infty \leq \varepsilon$,

ε is the uncertainty boundary, called stability margin.

According to the standard procedure of H_∞ loop shaping, the following steps can be applied to design the H_∞ loop shaping controller.

Step 1 Shape the singular values of the nominal plant G_o by using a pre-compensator W_1 and/or a post-compensator W_2 to get the desired loop shape. W_2 can be chosen as an identity matrix, since we can neglect the sensor noise effect when the use of good sensor is assumed [10]. Weight selection is very important for the design. Typically, weight W_1 and W_2 are selected such that the open loop of the shaped plant has the following conflict properties:

- To achieve a good performance tracking, good disturbance rejection, large open loop gain (normally at low frequency range) is required.
- To achieve a good robust stability and sensor noise rejection, small open loop gain (normally at high frequency range) is required.

There are some guidelines for the weight selection in [10]. In SISO system, the weighting functions w_1 and w_2 can be chosen as

$$W_1 = K_w \frac{s + a}{s + b} \text{ and } W_2 = 1 \quad (3)$$

Where K_w , a and b are positive values

Step 2 Minimize ∞ -norm of the transfer matrix T_{zw} over all stabilizing controllers K , to obtain an optimal cost γ_{opt} , as [10]

$$\gamma_{opt} = \varepsilon_{opt}^{-1} = \inf_{stab K} \left\| \begin{bmatrix} I \\ K \end{bmatrix} (I + G_s K)^{-1} M_s^{-1} \right\|_\infty \quad (4)$$

$\varepsilon_{opt} \ll 1$ indicates that W_1 or W_2 designed in step 1 are incompatible with robust stability requirement. If ε_{opt} is not satisfied ($\varepsilon_{opt} \ll 1$), then return to step 1, adjust W_1 .

Step 3 Select $\varepsilon < \varepsilon_{opt}$ and then synthesize a controller K_∞ that satisfies

$$\|T_{zw}\|_{\infty} = \left\| \begin{bmatrix} I \\ K_{\infty} \end{bmatrix} (I + G_s K_{\infty})^{-1} M_s^{-1} \right\|_{\infty} \leq \varepsilon^{-1} \quad (5)$$

Controller K_{∞} is obtained by solving the optimal control problem. See [11] for more details.

Step 4 Final controller (K) follows

$$K = W_1 K_{\infty} W_2 \quad (6)$$

B. Genetic Algorithm based Fixed-Structure H_{∞} Loop Shaping Optimization

The controller, which is derived from H_{∞} loop shaping method, is complicated and high-order. It is difficult to apply this controller in real works. Nowadays, the fixed-structure robust controller becomes an interesting research area because of their advantages in simple structure and acceptable controller's order. In this paper, the genetic searching algorithm is adopted to solve this problem. Although the proposed controller is structured, it still retains the entire robustness and performance guarantee as long as a satisfactory uncertainty boundary ε is achieved. The proposed algorithm is explained as following.

Assume that the predefined structure controller $K(p)$ has a satisfied parameters p . Based on the concept of H infinity loop shaping, optimization goal is to find parameters p in controller $K(p)$ that minimize infinity norm $\|T_{zw}\|_{\infty}$. From (6), the controller $K(p)$ can be written as

$$K(p) = W_1 K_{\infty} W_2 \quad (7)$$

Assume that W_1 and W_2 are invertible, then

$$K_{\infty} = W_1^{-1} K(p) W_2^{-1} \quad (8)$$

the weight $W_2 = I$ which implies that sensor noise is negligible and not considered [10]. Thus,

$$K_{\infty} = W_1^{-1} K(p) \quad (9)$$

By Substitution of (9) into (5), then the ∞ -norm of the transfer function matrix from disturbances to states, $\|T_{zw}\|_{\infty}$, which is subjected to be minimized can be written as

$$J_{cost} = \gamma = \|T_{zw}\|_{\infty} = \left\| \begin{bmatrix} I \\ W_1^{-1} K(p) \end{bmatrix} (I + G_s W_1^{-1} K(p))^{-1} M_s^{-1} \right\|_{\infty} \quad (10)$$

In this paper, GA is adopted to find the optimal control parameters p^* in the stabilizing controller $K(p)$ such that the $\|T_{zw}\|_{\infty}$ is minimized. The optimization problem can be written as

$$\text{Minimize } \left\| \begin{bmatrix} I \\ W_1^{-1} K(p) \end{bmatrix} (I + G_s W_1^{-1} K(p))^{-1} M_s^{-1} \right\|_{\infty} \quad (11)$$

Subject to

$$p_{i,\min} < p_i < p_{i,\max}$$

Where $p_{i,\min}$ and $p_{i,\max}$ are the lower and upper bound values of the parameter p_i in controller $K(p)$, respectively.

Genetic Algorithms

Our proposed technique uses GA to solve the optimization problem in (11). GA is well known as a biologically inspired class of algorithms that can be applied to any nonlinear optimization problem. This algorithm applies the concept of chromosomes, and the operations of crossover, mutation and reproduction. At each step, called generation, fitness values of all chromosomes in population are calculated. Chromosome, which has the maximum fitness value (minimum cost value), is kept as a solution in the current generation and passed to the next generation. The new population of the next generation is obtained by performing the genetic operators such as crossover, mutation, and reproduction. Crossover randomly selects a site along the length of two chromosomes, and then splits the two chromosomes into two pieces by breaking them at the crossover site. The new chromosomes are then formed by matching the headpiece of one chromosome with the tailpiece of the other. Mutation operation forms a new chromosome by randomly changing value of a single bit in the chromosome. Reproduction operation forms a new chromosome by just copying the old chromosome. Chromosome selection in genetic algorithm depends on the fitness value. High fitness value means high chance to be selected. Operation type selection; mutation, reproduction, or crossover, depends on the pre-specified operation's probability.

Chromosome in genetic population is coded as binary number. However, for the real number problem, decoding binary number to floating number is applied [12].

Our proposed algorithm is summarized as

Step 1 Shape the singular values of the nominal plant G_o by W_1 and W_2 . Then evaluate the ε_{opt} using (4). If $\varepsilon_{opt} < 0.25$, then go to step 1 to adjust the weight W_1 .

Step 2 Select a controller structure $K(p)$ and initialize several sets of parameters p as population in the 1st generation. Define the genetic parameters such as initial population size, crossover and mutation probability, maximum generation, etc.

Step 3 Evaluate the cost function J_{cost} of each chromosome using (10). Assign $J_{cost} = 100$, or large number if $K(p)$ does not meet the constraints in our optimization problem. The fitness

value is assigned as $\frac{1}{J_{cost}}$. Select the chromosome with

minimum cost function as a solution in the current generation. For the first generation, Gen = 1.

Step 4 Increment the generation for a step.

Step 5 While the current generation is less than the maximum generation, create a new population using genetic operators and go to step 3. If the current generation is the maximum generation, then stop.

Step 6 Check performances in both frequency and time domains. If the performance is not satisfied, such as too low ε (too low fitness function), then go to step 3 to change the control structure. Low ε indicates that the selected control structure is not suitable for the problem.

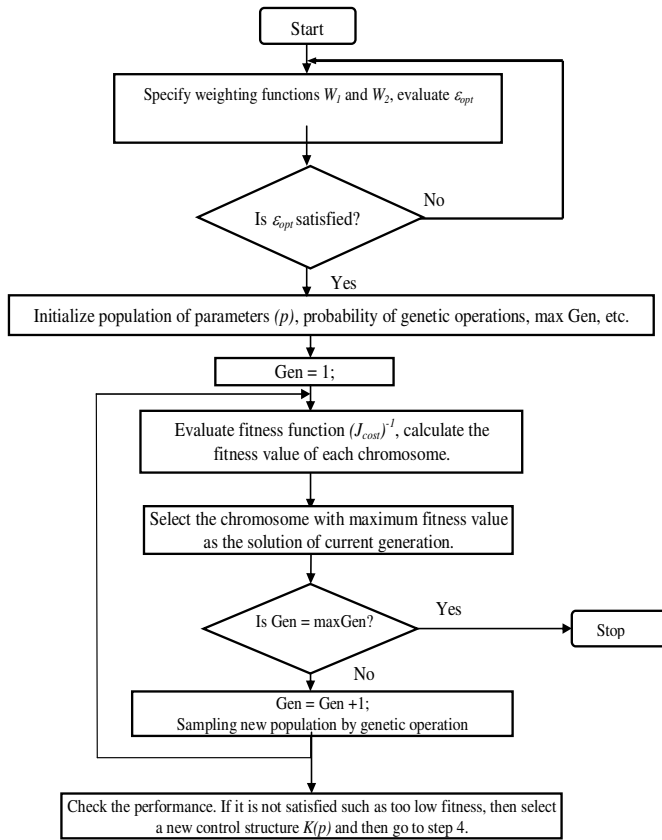

Fig. 3. Flow chart of the proposed design procedure.

IV. SIMULATION AND EXPERIMENTAL RESULTS

In this paper, a buck-boost converter designed for a photovoltaic system is studied. Converter's parameters and considered variation ranges used in this paper are given in Table 1.

Table 1 Converter's parameters and considered variation ranges.

Parameter	Name	Nominal Value
R_L	Load Resistant	40 Ω
V_o	Output Voltage	30 V
V_i	Input Voltage	12 V
L	Inductance	100 μ H
C	Capacitor	470 μ F
f_{sw}	Switching frequency	100 kHz

By (1), the nominal transfer function is found to be

$$G_o = \frac{(-0.0042s + 480)}{(0.7896s + 72)} \quad (12)$$

Both H_∞ loop shaping control and our proposed technique are applied to this converter. Firstly, we design a controller by the conventional H_∞ loop shaping procedure. In this case, W_1 is selected as

$$W_1 = 25 \frac{(s + 30)}{(s + 10)} \quad (13)$$

W_2 is chosen as 1 since we neglect the sensor noise effect when the use of good sensor is assumed. Fig. 4 (a) shows the plot of open loop shape of nominal plant and shaped plant. As seen in this figure, the bandwidth of the nominal plant is about 600 rad/sec. With these weighting functions, bandwidth of the desired control system is increased to 15,000 rad/sec. Significant performances and robustness improvement are carried out by these weighting functions.

The shaped plant is written as

$$G_s = L = W_1 G W_2 = 25 \frac{(s + 30)(-0.0042s + 605.6)}{(s + 10)(0.9963s + 72)} \quad (14)$$

By applying the H_∞ loop shaping method, the optimal stability margin (ϵ_{opt}) is founded at 0.708 ($\gamma_{opt} = 1.4123$). This value indicates that the selected weighting function is compatible with the robust stability requirement. The $\epsilon = 0.66123$ ($\gamma = 1.5123$), which is less than the optimal stability margin, is chosen to synthesis the controller. Based on the conventional technique is section II, the conventional H_∞ loop shaping controller is synthesized as following

$$K(s) = W_1 K_\infty W_2 = \frac{4.599 \times 10^6 s^2 + 2.763 \times 10^8 s + 4.15 \times 10^9}{s^3 + 1.845 \times 10^5 s^2 + 7.386 \times 10^6 s + 5.541 \times 10^7} \quad (15)$$

As shown in (15), the controller is 3th order controller and complicated structure.

Next, PI controller is investigated as a fixed-structure controller. The controller structure is expressed in (16). K_p and K_i are parameters that will be evaluated.

$$K(p) = K_p + \frac{K_i}{s} \quad (16)$$

Select the controller parameters, their ranges, and genetic algorithms parameters as following: $K_p \in [0, 200]$, $K_i \in [0, 1000]$, population size = 100, crossover probability = 0.7, mutation probability = 0.25, and maximum generation = 30. An optimal solution is obtained after 18 generations. The optimal solution is shown in (17), which has stability margin (ϵ) of 0.65918 ($\gamma = 1.5171$).

$$K(p)^* = 21.88 + \frac{989.7}{s} \quad (17)$$

Fig. 5 shows plots of convergence of cost function J_{cost} versus generations by genetic algorithm. As seen in this figure, the optimal fixed-structure controller provides the satisfied stability margin at 0.65918 ($\gamma = 1.5171$).

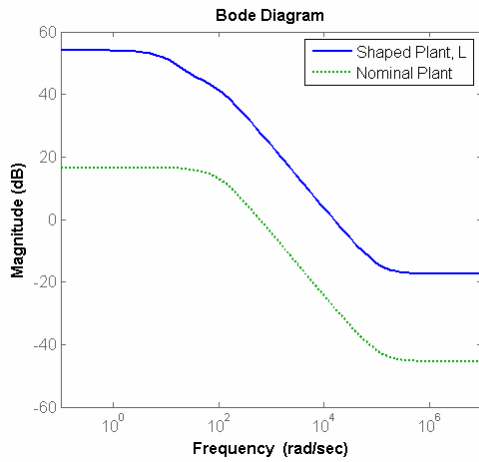

(a)

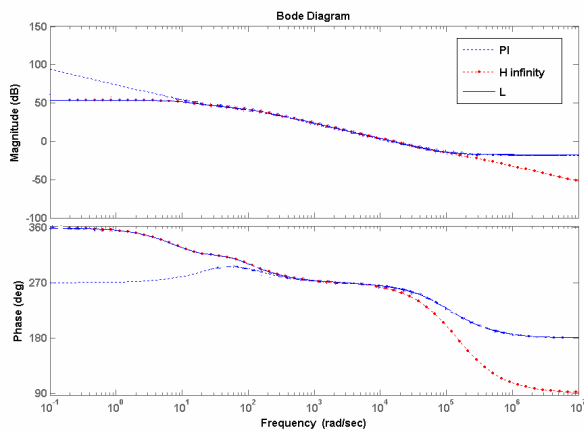

(b)

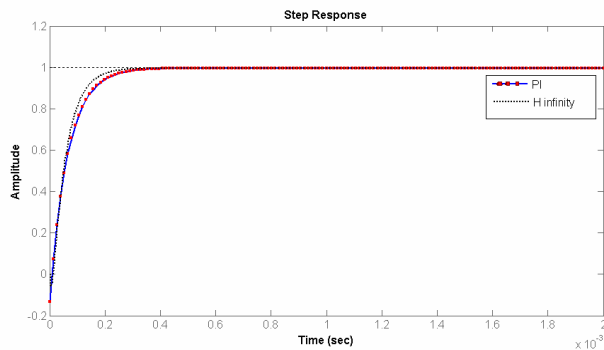

(c)

Fig. 4. (a) Bode plots of the nominal plant and the shaped plant (desired loop shape, L) (b) The desired loop shape and the loop shape by the conventional H_∞ loop shaping and the proposed PI, (c) Step responses by the proposed PI and H_∞ loop shaping controllers.

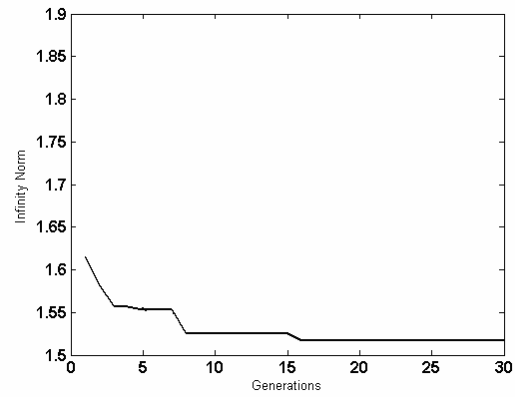

Fig. 5 Cost functions J_{cost} versus iteration in genetic algorithm.

The open loop bode diagrams of the nominal and shaped plants are shown in Fig. 4(a). As shown in this figure, at low frequency, the open loop gain of shaped plant is much larger than that of the nominal plant. This makes the designed system has good performance tracking and good disturbance rejection. Open loop bode diagrams are plotted in Fig. 4(b) to verify the proposed algorithm. It is clearly shown that the loop shapes of H_∞ control and PI are close to the desired loop shape. Fig. 4(c) shows the step responses of the optimal solutions from the proposed robust PI and the conventional H_∞ controllers. As shown in this figure, the settling time of all responses is about 350 μsec .

To verify the robust performance, we change the converter's parameters as: $R_L = 10 \Omega$, $V_i = 10.8 \text{ V}$, $L = 120 \mu\text{H}$ and $C = 611 \mu\text{F}$. The designed controller in (15) and (17) is adopted to control this perturbed plant. Obviously, this condition (increase the L and C and decrease the load and input voltage) is worse than the nominal condition. In this case, for simulation, the plant is changed to

$$G = \frac{(-0.004896s + 129.6)}{(0.2938s + 70.8)} \quad (18)$$

Fig. 6 shows the step responses of all controllers in the perturbed plant. The responses are almost the same as the responses in the nominal plant with some different in the setting time. The results show that the designed system from the proposed controller and H_∞ loop shaping has a good performance and robustness.

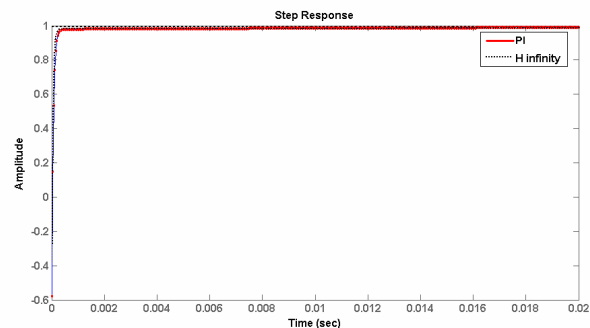

Fig. 6 Step responses in the perturbed plant. ($R_L = 10 \Omega$, $V_i = 10.8 \text{ V}$, $L = 120 \mu\text{H}$ and $C = 611 \mu\text{F}$).

Some experiments are performed to verify the effectiveness of the proposed controller. The nominal values in Table 1 are used to design a buck boost converter with current mode control. A proposed controller, robust PI controller in (17) is used to control the converter. Fig. 7 shows the experimental result of step response of the proposed controller. The settling time of the response is about 350 μ sec. As seen in Fig. 4(c) and Fig. 7, the response of experimental result is almost the same as that of the simulation result.

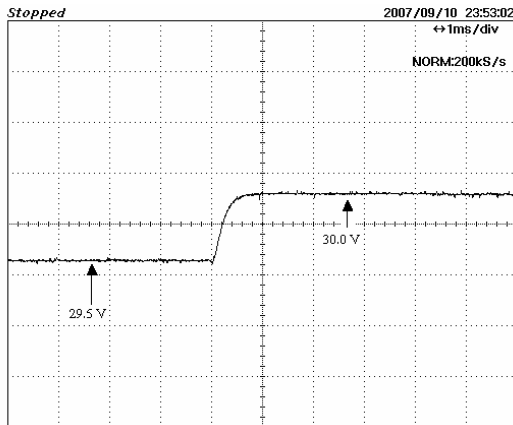

Fig. 7 Step response in the closed loop in nominal conditions for proposed PI controller.

To verify the robust performance of the system, an experiment is performed. The component values and operating points of converter are changed to: $R_L=10 \Omega$, $V_i=10.8 \text{ V}$, $L=120 \mu\text{H}$ and $C=611 \mu\text{F}$. The controller from the previous experiment is used to control this perturbed plant. The performance is verified by using the step response. As shown in Fig. 8, the step response is almost the same as the response in nominal conditions. This response is over damp response with a small different in the settling time. Experimental results verify that the proposed controller can be applied for the buck-boost converter to achieve a good robust performance.

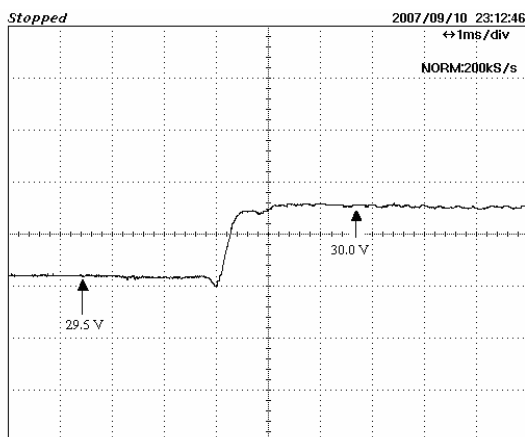

Fig. 8 Step response in the closed loop in perturbed conditions for the proposed PI controller.

V. CONCLUSION

Both of H_∞ loop shaping and the proposed technique can be applied to design a robust controller for a buck boost converter. However, the proposed approach significantly improves in practical control viewpoint by simplifying the controller structure, reducing the controller order and retaining the robust performance. Although the proposed controller is structured, it still retains the entire robustness and performance guarantee as long as a satisfactory uncertainty boundary ε is achieved. Structure of controller in the proposed technique is selectable. This is desirable, especially in the DC-DC converter which analog circuit is normally used to design the controller. In conclusion, by combining of the approaches, genetic algorithms and H_∞ loop shaping; fixed-structure controller design can be designed. Implementation in buck-boost converter assures that the proposed technique is valid and flexible.

ACKNOWLEDGMENT

This research work is financially supported by the Thailand Research Fund (Project. No. MRG4980087) and the research fund from the faculty of engineering, King Mongkut's Institute of Technology Ladkrabang.

REFERENCES

- [1] Simone Buso, "Design of a Robust Voltage Controller for a Buck-Boost Converter Using μ -Synthesis," *IEEE Trans. On Control Systems Technology*, Vol. 7, No. 2, pp. 222-229, March 1999.
- [2] R. B. Ridley, "A new continuous-time model for current-mode control," in *Power Conversion Intell. Motion (PCIM) Conf. Proc.*, 1989, pp.455-464.
- [3] J. G. Kassakian, M. F. Schlecht, and G. C. Verghese, *Principles of Power Electronics*. Reading, MA: Addison-Wesley, 1991.
- [4] NAIM, R., WEISS, G., and BEN-YAAKOV, S., "H ∞ control of boost converters: comparison to voltage mode, feed-forward and current mode controls". *PESC'95*, Atlanta, USA, pp. 1327-1332, June 1995.
- [5] G.C. Ioannidis, S.N.Manias, "H ∞ loop-shaping control schemes for the buck converter and their evaluation using μ -analysis," *IEE Proc.-Electr. Power Appl*, Vol. 146. No. 2, March 1999.
- [6] Bor-Sen Chen and Yu-Min Cheng, "A Structure-Specified optimal Control Design for Practical Applications: A Genetic Approach," *IEEE Trans. on Control System Technology*, Vol. 6, No. 6, November 1998.
- [7] Bor-Sen Chen, Yu-Min Cheng and Ching-Hsiang Lee, "A Genetic Approach to Mixed H $_2$ / H ∞ Optimal PID Control," *IEEE Trans. on Control Systems*, p. 51-60, 1995.
- [8] Shinn-Jang Ho, Shinn-Ying Ho, Ming-Hao Hung, Li-Sun Shu, and Hui-Ling Huang. Designing Structure-Specified Mixed H $_2$ / H ∞ Optimal Controllers Using an Intelligent Genetic Algorithm IGA. *IEEE Trans. on Control Systems* 2005; 13(6):1119-24.
- [9] McFarlane, D.C. & K. Glover, "A loop shaping design procedure using H ∞ synthesis," *IEEE Trans. On Automatic Control* AC-37 (6):759-769, 1992.
- [10] Kemin Zhou, Jhon C. Doyle, 1998. *Essential of Robust Control*. Prentice-Hall, pp 315-327.
- [11] Sigurd Skogestad, Ian Postlethwaite, *Multivariable Feedback Control Analysis and Design*. John Wiley & Son, pp.118,376-380, 1996.
- [12] Chris Houck, Jeff Joines, and Mike Kay, "A Genetic Algorithm for Function Optimization: A MATLAB Implementation" by, NCSU-IE TR 95-09, 1995.