

On Vector Fitting Methods in Signal/Power Integrity Applications

Chi-Un Lei[†], Yuanzhe Wang, Quan Chen and Ngai Wong

Abstract—Vector Fitting (VF) has been applied to reformulate traditional system identification techniques by introducing a partial-fraction basis to avoid ill-conditioned calculation in broadband system identifications. Because of the reliable and versatility of VF, many extensions and applications have been proposed, for example, the macromodeling of linear structures in signal/power integrity analyses. In this paper, we discuss the macromodeling framework and some main features in VF in terms of data, algorithms and models. Finally, an alternative P -norm approximation criterion is proposed to enhance the macromodeling process.

Index Terms—Signal/Power Integrity, Vector Fitting, Macromodeling, Tutorial, Approximation

I. INTRODUCTION

Vector Fitting (VF) [1] is a numerical technique for sampled response-matching system identification (macromodeling), which involves iterative linear least-squares solves with a partial fraction basis. As opposed to other system identification techniques for broadband (from DC to GHz) system identification, VF avoids ill-conditioned calculation, and therefore works in a more robust and efficient manner. Furthermore, its theoretically-simple and versatile framework can easily incorporate various constraints by introducing a variety of extensions for other areas. VF has also been used in modeling of different electrical systems [1], [2] and extended to different areas, for example, filter design [3]–[5], power network analysis [2], [6] and electromagnetic (EM) simulation [7].

The idea of VF was firstly introduced for transmission line transient modeling in [8]. The underlying idea of VF is to replace the approximated (or initialized) poles with an improved set of poles through implicit weighting (the pole relocation technique), which thereby improves the approximation iteratively. VF approximates an underlying system to a new system using partial fraction basis with real or complex conjugate poles. A number of generalizations and extensions have been proposed for better VF performance and integration with various identification requirements [9]–[24]. VF has been thoroughly discussed in [25], [26]. Its basic implementation is available from [27], whereas its variants have been widely used in industrial electronic design workflows for signal integrity issues [28]–[30].

This paper acts as a tutorial on VF. We first give a brief introduction to the signal/power integrity issues (Section II)

[†]Corresponding Author.

C-U. Lei, Y. Wang, Q. Chen and N. Wong are with the Department of Electrical and Electronic Engineering, The University of Hong Kong, Pokfulam Road, Hong Kong. Phone: ++852 +2859 2698 Fax: ++852 +2559 8738 Email: {culei, yzwang, quanchen, nwong}@eee.hku.hk

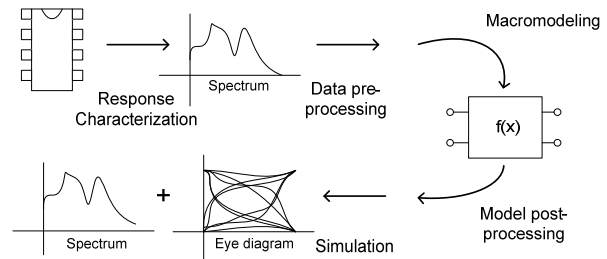

Fig. 1. Common macromodeling flow in signal integrity analyses.

and basic formulation of VF (Section III). Then we discuss the applications of VF in system identification (Sections IV, V and VI). Finally an alternative P -norm approximation criterion in VF is proposed for approximation enhancement (Section VII), which is verified through numerical examples (Section VIII).

II. MACROMODELING: SYSTEM IDENTIFICATION PROBLEM IN SIGNAL/POWER INTEGRITY

With the increasing operational frequency and decreasing size of integrated circuits (ICs), high-frequency effects, such as signal delay and crosstalk, have become dominant factors limiting system performance in IC design. Accurate and efficient simulation is required to capture the high-frequency behavior of systems, so as to ensure consistent transmissions and reliable ground (and power) distributions in high-speed electronic systems [2], [31]. A common simulation flow is shown in Fig. 1. The sampled structure responses can be obtained by exciting one input port at a time and computing or measuring the responses at the output ports (**Response Characterization**). By approximating the sampled frequency-dependent or time-dependent system response data, a macromodel is generated to replace the original large-order system by a smaller-order one with similar input-output relationship (**Macromodeling**). The macromodel is used to generate spectra and waveforms for signal integrity analysis or coupled with other circuit model blocks (e.g., logic devices) for global simulation (**Simulation**). Peripheral pre-processing and post-processing techniques are used to rectify the macromodel characteristics and enhance the simulation performance.

Generally, for a single-port (one input port and one output port) system, macromodeling techniques intend to fit a linear-time invariant (LTI) system to the desired continuous-time frequency-sampled response $H(s)$ at a set of calculated/sampled points at the input and output ports. The model

and the residues $\{c_n^{(N_T)}\}$ and $d^{\{N_T\}}$ can be calculated similarly as in (8). In summary, VF replaces the monomial power series basis by a partial fraction basis, which significantly improves the numerical condition in calculation of (8). The detailed VF formulation is shown in [1], [9], [10]. Pseudocodes are given to summarize the framework of VF:

Algorithm 1 Pseudocodes of Vector Fitting (VF)

- 1: Find $H(z)$, and assign $\{\alpha_n^{(0)}\}$;
 - 2: **repeat**
 - 3: Calculate $\{\gamma_n^{(t)}\}$ by solving (8) with $\{\alpha_n^{(t)}\}$;
 - 4: Calculate $\{\alpha_n^{(t+1)}\}$ by solving (9) and stabilize the unstable poles through (10);
 - 5: **until** $\{\alpha_n^{(t)}\}$ converges after N_T iterations
 - 6: Calculate $\{c_n^{(N_T)}\}$ and $d^{\{N_T\}}$ through (12) with $\{\alpha_n^{(N_T)}\}$;
-

IV. DATA

Data describe the system response, and are obtained from measurements (e.g., vector network analyzer (VNA)) or EM simulators (e.g., Nexxim [30]). Since data content can affect the properties and quality of the macromodel, different considerations and techniques have been proposed to ensure the input data are maximally informative for identification.

A. Input data choices

Continuous-time frequency-sampled data $H(s)$ are used for macromodeling in VF [1], as the frequency-sampled responses capture the high-frequency behaviors of the system. Examples of frequency-sampled data are scattering parameters (S -parameters) for RF objects and admittance parameters (Y -parameters) for interconnects. Alternative data choices, such as frequency response derivative $H'(s)$ [15], phase response $\angle H(s)$ [16] and magnitude response $|H(s)|$ [17], are used for different identification purposes. In practices, frequency-domain macromodeling involves complicated measurements. Truncated time-sampled data (input and output response $X[n]$ and $Y[n]$) are often used, therefore (discrete) time-domain VF have been proposed [13], [14]. Approximation using combination of several classes of data (hybrid-domain approximation) provides extra system information for a more accurate approximation. It has been applied to digital IIR filter approximation [4] and works well in macromodeling process.

B. Pre-processing of data

The system response should correctly describe the system. However, some problems, such as data burst, defects, missing and noise-disturbance, may happen during data collection. Some information may get lost and difficulties and failures in approximation may arise. Therefore, data pre-processing is required to ensure the data are meaningful (e.g., passive and

causal, as explained in Section VI-A) to generate a correct macromodel. For example, causality and passivity verification of input data and delay extraction using (generalized) Hilbert transform [35] are developed. Furthermore, causality-constrained data interpolation is developed to generate consistent DC and low-frequency data, which is necessary for simulation but usually not provided in the frequency-sampled data [35].

In addition, a large data set or broadband responses usually have a large variance and may result in ill-conditioned calculation. Pre-filtering techniques, in this scenario, can be used to change the distribution of noise and bias, so as to give a better fitting of important frequency range and a numerically favorable calculation with a small computational cost. An appropriate adaptive or deterministic data selection process and response weighting can also be applied for a better approximation.

C. Pre-processing of model

A priori configuration of macromodels should be chosen based on the knowledge of the algorithms (SK iteration) and data for a convenient approximation. For example, an *a priori* model order selection helps generate a minimum size macromodel for efficient simulations with accuracy control. The model order can be selected by applying experimental observation of the frequency response in frequency-sampled data [18], or the Hankel Singular Value (HSV) in (discrete) time-sampled data [14].

V. ALGORITHMS

Given a set of input data, an algorithm is used to determine the model parameters. A good algorithm should have an appropriate identification criterion and should be easy and robust for numerical implementation. We first discuss the algebraical minimization criteria, then the numerical implementation for a numerically favorable model parameters calculation.

A. Identification criterion and framework

The selection of the approximation criteria is important for model approximation. The model should be reliable, obtained within a reasonable computation time, and should admit an exact description of the true system. SK iteration with an L_2 -norm prediction error is usually used since it is applicable to different response models. Other criterion extensions are also developed recently for specific applications.

Massive-port macromodeling: VF handles multi-port macromodeling by stacking the system equation matrices of responses of all ports into a single column of over-determined equation for solutions. However, numerical difficulties exist in modeling the systems with a large number of ports (e.g., package parasitic networks and electromagnetic-aware circuits). To model a system with an arbitrary number of ports, a reformation of the VF framework is proposed to approximate the eigenpairs rather than the matrix elements [20]. It gives a more accurate approximation for systems with a large ratio between the largest and smallest eigenvalues.

Parametric macromodeling: Variabilities in geometry and material properties are generated during the manufacturing process, and become a critical factor in nano-scale high-frequency circuit simulation and design. In order to accurately predict the behavior and reduce the computation time of repeated simulations, a parametric macromodel is used to describe the variational structures

$$H(s, g) \approx \frac{\sum_{n=0}^{N_s} \left(\sum_{p=1}^P b_{np} \varphi_p(g) \right) \phi_n(s)}{\sum_{n=0}^{N_s} \left(\sum_{p=1}^P \tilde{b}_{np} \varphi_p(g) \right) \phi_n(s)}, \quad (13)$$

where $\phi_n(s)$ is the frequency-dependent basis and $\varphi_p(g)$ is the variability-dependent basis with a single variational parameter g and P samples in the variability domain. The variational structures can be described by a macromodel with a polynomial basis or rational function basis [23], [24], [26].

B. Numerical Implementation

Due to the nature of iterative calculation, its implementation is usually numerically sensitive. Although VF solves the ill-conditioned calculation by a partial-fraction basis, other problems, such as inappropriate initial guess and noise-contaminated responses, damage the algorithm convergence. Some improvements have been proposed to alleviate these problems.

Initial poles and applied basis: The algorithm gives a set of model parameters (b_n and \tilde{b}_n in (1)) according to the given set of basis ($\phi(s)$), the sampled data and the initial poles. The selected basis affects the conditioning of the system equation matrix in (8) and the accuracy of the solution.

One approach to address this problem is to select an appropriate set of initial poles. The initial poles can be obtained by a simple calculation (e.g., Prony method [32]), or intuitively assigned as a set of weakly-damped initial poles ($\alpha_{1,2} = a \pm j0.01a$) [1]. Another approach is to select a robust basis for calculation, which minimizes the numerical disturbance due to the inappropriate set of poles. Orthonormal basis $\phi_{or_n}(s)$ [11] and discrete-time domain (z -domain) basis $\phi_{z_n}(z)$ [3] have been proposed based on this idea, namely,

$$\phi_{or_n}(s) = \kappa_n \sqrt{2\Re(\alpha_n)} \left(\prod_{j=1}^{n-1} \frac{s - \alpha_j^*}{s + \alpha_j} \right) \frac{1}{s + \alpha_n}, \quad (14)$$

$$\phi_{z_n}(z) = \frac{1}{z^{-1} + \alpha_n}, \quad (15)$$

where κ_n is the normalization coefficient and $*$ denotes complex conjugate. Orthonormal basis, from a mathematical perspective reduces the condition number of the system equation matrix, while the discrete-time basis calculation maps the left Laplace plane to a unit circle plane, and thus improves the numerical condition from a signal-processing perspective. Furthermore, discrete-time domain orthonormal basis is proposed recently for further robustness improvement [12]. Other basis generalizations are also available for different requirements, e.g., modeling the responses with repeated poles [11] and time-sampled data [13], [14].

Macromodeling with noisy signals: Experiences show that the convergence is severely impaired in noise-contaminated signals and biased in the low-frequency region. This is because the unity basis of $\sigma(s)$ in (6) impairs the LS normalization of equation solving. To address this problem, a variable unity basis (γ_0) normalization (16) with an additional relaxed nontriviality condition (17) is adopted for a relaxed least-squares normalization (Relaxed VF) [10], [19],

$$\underbrace{\left(\sum_{n=1}^N \frac{c_n^{(t)}}{s + \alpha_n^{(t)}} \right) + d_n^{(t)}}_{(\sigma H)^{(t)}(s)} \approx \underbrace{\left(\left(\sum_{n=1}^N \frac{\gamma_n^{(t)}}{s + \alpha_n^{(t)}} \right) + \gamma_0 \right)}_{\sigma^{(t)}(s)} H(s), \quad (16)$$

$$\Re \left(\sum_{k=1}^{N_s} \left(\sum_{n=1}^N (\gamma_n \phi_n(s_k)) + \gamma_0 \right) \right) = N_s + 1. \quad (17)$$

Eq. (17) imposes that the sum of the samples approaches to a nonzero value. This improves the normalization of the transfer function coefficients and the linearization of the iterative SK iteration without affecting the convergence.

Massive-port macromodeling: VF suffers from computational inefficiency when macromodeling massive-port systems due to the unnecessary calculation of c_n in (8) during iterative pole calculation (Step 3). Based on the observation of shared common poles in the macromodel, a QR decomposition is applied to extract the calculation of γ_n of each port response and formulate a compacted calculation [21]. The computational complexity is then reduced from $O((P_{in}P_{out} + 1)^2 n^2 N_s P_{in} P_{out})$ to $O(n^2 N_s P_{in} P_{out})$ for a system with P_{in} input ports and P_{out} output ports, without any loss of accuracy.

VI. MODELS

The macromodel (model) describes the Input-Output (I/O) characteristics of the approximated system, for analysis and coupled simulation with other circuit models. The model should be accurate, physically consistent and of low complexity for simulation. Necessary post-processing techniques are adopted to ensure a correct simulation.

A. Post-processing for a physically consistent model

The macromodel should be physically consistent, i.e., real-valued, stable, passive and causal [36].

Real-valued: Real-valued macromodels do not generate complex-valued responses for real-valued input data. However, the original VF may generate complex-valued macromodels if the complex poles are not restricted to conjugate pairs. Some modifications in (7)-(9) are required to construct a real-valued macromodel, as explained in [1]. Complex-valued computations of (8) are separated into its real and imaginary parts to avoid numerical errors, at the expense of an increased problem size.

Stable: Stable macromodels do not generate response beyond limits for any input signal. An unstable pole can be stabilized through a non-linear pole flipping in (11). The flipping, however, does not affect the norm criterion in (3) and the algorithm convergence.

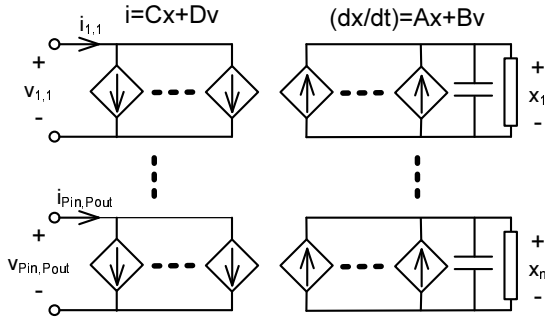

Fig. 2. Equivalent circuit realization of a P_{in} -input-ports and P_{out} -output-ports system ($\mathbf{i} = \mathbf{C}\mathbf{x} + \mathbf{D}\mathbf{v}$ and $\frac{d\mathbf{x}}{dt} = \mathbf{A}\mathbf{x} + \mathbf{B}\mathbf{v}$), formed by the sampled admittance data.

Passive: Passive macromodels do not generate energy, yet VF may generate slightly non-passive macromodels due to numerical errors. Therefore, passivity enforcement through perturbation of model parameters is required to passify the model, and a detailed study is shown in [37].

Causal: Causal macromodels do not generate output signal according to the future input. However, modeling electrically-long structures (i.e., responses with a signal delay) using a purely rational macromodel may suffer from inapplicable fitting and often generates a non-causal model. A reformulated VF is developed [22]. With the D obtained time delays $\{\tau_d\}$, the response can be fitted via

$$H(s) \approx \frac{\sum_{n=0}^N \sum_{d=1}^D b_{nd} \phi_n(s) e^{-s\tau_d}}{\sum_{n=0}^N \tilde{b}_{nd} \phi_n(s)}. \quad (18)$$

B. Post-processing for simulation

The approximant macromodel is used to generate the frequency response, time-domain reflectometry (TDR) waveforms, time-domain transmissometry (TDT) waveforms and eye diagrams for channel analysis, or coupled with other models for overall simulation. Therefore, the models should be fully integrated with simulation tools for efficient analysis. The macromodel can be described by a pole-residue form in Matlab Simulink or Verilog-A description for high-level simulation. The macromodel can also be described as an equivalent circuit in a SPICE netlist for co-simulation with other (non-linear) macromodels [38]. A standard equivalent circuit in Fig. 2 can be generated using differential-equation realization.

VII. P-NORM APPROXIMATION IN VF

To satisfy different macromodeling requirements and give a more realistic description of the system, the approximation framework (3) is extended to a P -norm (L_p) approximation. The minimization framework (3) is generalized to

$$\min \left\| \frac{N^{(t)}(s)}{D^{(t-1)}(s)} - \frac{D^{(t)}(s)}{D^{(t-1)}(s)} H(s) \right\|_p, \quad (19)$$

for which the over-determined equations can be efficiently solved by convex programming. The approximation framework can be generalized to a user-defined norm (e.g., region-dependent norm) approximation or (norm-)constrained approximation to meet different macromodeling requirements. For example, L_∞ (Chebyshev norm) approximation gives a smaller

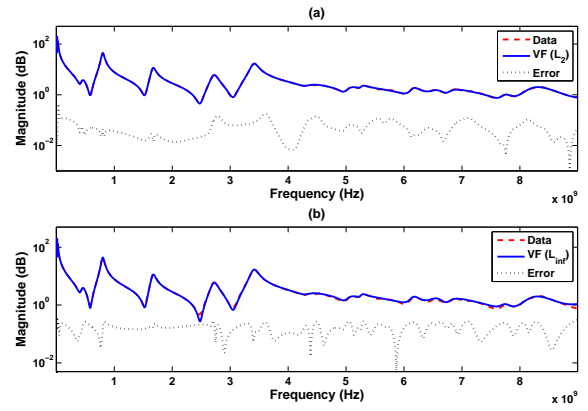

Fig. 3. Magnitude responses of the power distribution network: (a) approximation using L_2 norm, and (b) approximation using L_{inf} (L_∞) norm.

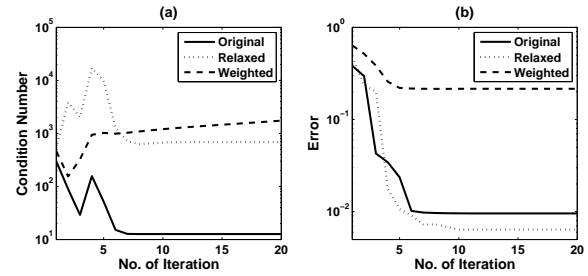

Fig. 4. (a) Condition number of the system equation matrix in (8), and (b) L_2 error of the approximation using original VF (6), relaxed VF (16) and weighted VF.

macromodel for a linear-phase (time-delayed) response, L_2 approximation gives a more accurate macromodel for a noisy response, and L_1 approximation is favorable for system identification with an impulsive-noise-contaminated signal.

VIII. NUMERICAL EXAMPLES

The VF is coded in Matlab m-script files and run in the Matlab 7.5 on a 1GB-RAM 3.4GHz PC. The example arises from a power distribution network of an IC power plane [2], whose admittance responses range from DC to 9GHz. The port response is fitted using relaxed VF [19] with a 35th-order macromodel with 10 iterations (18.28 seconds) and a set of linear-spaced initial poles, which gives 0.0064 L_2 and 0.0022 L_∞ error in fitting. Fig. 3 plots the magnitude-domain responses of the converged approximant. Fig. 4 shows the condition number of the system equation matrix (8) and the L_2 error during iterations. In general, VF converges quickly (≤ 10 iterations), especially for minimum-phase (passive) response. For further analysis of generalizations of VF, we repeat the example using VF without relaxed constraint and relaxed VF with a inverse-magnitude weighting. The quantitative comparison is shown in Fig. 4. It shows that the weighting does not contribute much to the numerical condition, but it affects the convergence. The relaxation may affect the numerical condition of the calculation, but it also significantly improves the accuracy of the approximation. At last, we repeat the example under an SNR of -35dB. In this case, relaxed VF

converges with 0.0193 L_2 and 0.0014 L_∞ error. This shows the relaxed VF is robust to the noisy response approximation.

The responses are also fitted using L_∞ norm approximation with the same configuration and clean signal, which gives an approximation with 0.0165 L_2 error and 0.0016 L_∞ error. The magnitude-domain response of the converged approximation in Fig. 3 shows that L_∞ -norm approximation renders a more accurate low-frequency (near DC) approximation which is important for simulation, and P -norm approximation can be used as an alternative approximation criterion.

IX. CONCLUSIONS

By applying a partial fraction basis, Vector Fitting (VF) has demonstrated its numerical robustness in broadband system identification. The good performance and versatile extensibility of VF render it an attractive tool for signal/power integrity analyses. In this paper, different issues related to VF have been discussed for obtaining a good macromodel for simulation. Furthermore, a P -norm approximation criterion is proposed to provide an alternative measure to meet different requirements.

ACKNOWLEDGMENTS

The work was supported in part by the Hong Kong Research Grants Council (HKU 718509E and HKU 717407E) and the University Research Committee of The University of Hong Kong.

REFERENCES

- [1] B. Gustavsen and A. Semlyen, "Rational approximation of frequency domain responses by vector fitting," *IEEE Trans. Power Delivery*, vol. 14, no. 3, pp. 1052–1061, July 1999.
- [2] M. Swaminathan and A. E. Engin, *Power Integrity Modeling and Design for Semiconductors and Systems*, Prentice Hall PTR, 2007.
- [3] N. Wong and C. U. Lei, "IIR approximation of FIR filters via discrete-time vector fitting," *IEEE Trans. Signal Process.*, vol. 56, no. 3, pp. 1296–1302, Mar. 2008.
- [4] C. U. Lei and N. Wong, "IIR approximation of FIR filters via discrete-time hybrid-domain vector fitting," *IEEE Signal Process. Lett.*, vol. 16, no. 6, pp. 533–537, June 2009.
- [5] C. U. Lei et al., "Efficient design of arbitrary complex response continuous-time IIR filter," in *Trends in Communication Technologies and Engineering Science*, Apr. 2009, pp. 163–176, Springer.
- [6] W. Zhang et al., "Efficient power network analysis considering multidomain clock gating," *IEEE Trans. Comput.-Aided Design Integr. Circuits Syst.*, vol. 28, no. 9, pp. 1348–1358, Sept. 2009.
- [7] Y. Cai and C. Mias, "Faster 3D finite element time domain - floquet absorbing boundary condition modelling using recursive convolution and vector fitting," *IET Microwaves, Antennas and Propagation*, vol. 3, no. 2, pp. 310–324, Mar. 2009.
- [8] B. Gustavsen and A. Semlyen, "Simulation of transmission line transients using vector fitting and modal decomposition," *IEEE Trans. Power Delivery*, vol. 13, no. 2, pp. 605–614, Apr. 1998.
- [9] D. Deschrijver, B. Haegeman, and T. Dhaene, "Orthonormal vector fitting: A robust macromodeling tool for rational approximation of frequency domain responses," *IEEE Trans. Adv. Packag.*, vol. 30, no. 2, pp. 216–225, May 2007.
- [10] D. Deschrijver, B. Gustavsen, and T. Dhaene, "Advancements in iterative methods for rational approximation in the frequency domain," *IEEE Trans. Power Delivery*, vol. 22, no. 3, pp. 1633–1642, July 2007.
- [11] D. Deschrijver and T. Dhaene, "A note on the multiplicity of poles in the vector fitting macromodeling method," *IEEE Trans. Microw. Theory Tech.*, vol. 55, no. 10, pp. 736–741, Apr. 2007.
- [12] B. Nouri, R. Achar, and M. S. Nakhla, "z-domain orthonormal basis functions for physical system identifications," *IEEE Trans. Adv. Packag.*, Accepted for future publication.
- [13] S. Grivet-Talocia, "Package macromodeling via time-domain vector fitting," *IEEE Microwave Guided Wave Lett.*, vol. 13, no. 11, pp. 472–474, Nov. 2003.
- [14] C. U. Lei and N. Wong, "Efficient linear macromodeling via discrete-time time-domain vector fitting," in *Proc. Intl. Conf. on VLSI Design*, Jan. 2008, pp. 469–474.
- [15] T. Dhaene and D. Deschrijver, "Generalised vector fitting algorithm for macromodelling of passive electronic components," *IEE Electronics Letters*, vol. 41, no. 6, pp. 299–300, Mar. 2005.
- [16] L. De Tommasi, D. Deschrijver, and T. Dhaene, "Transfer function identification from phase response data," *AEU International Journal of Electronics and Communications*, 2010, Accepted for future publication.
- [17] W. Hendrickx, D. Deschrijver, L. Knockaert, and T. Dhaene, "Magnitude vector fitting to interval data," *Mathematics and Computers in Simulation*, vol. 80, no. 3, pp. 572–580, Nov. 2009.
- [18] N. Stevens, D. Deschrijver, and T. Dhaene, "Fast automatic order estimation of rational macromodels for signal integrity analysis," in *Proc. IEEE Workshop on Signal Propagation on Interconnects*, May 2007, pp. 89–92.
- [19] B. Gustavsen, "Improving the pole relocating properties of vector fitting," *IEEE Trans. Power Delivery*, vol. 21, no. 3, pp. 1587–1592, July 2006.
- [20] B. Gustavsen and C. Heitz, "Modal vector fitting: A tool for generating rational models of high accuracy with arbitrary terminal conditions," *IEEE Trans. Adv. Packag.*, vol. 31, no. 4, pp. 664–672, Nov. 2008.
- [21] D. Deschrijver et al., "Macromodeling of multiport systems using a fast implementation of the vector fitting method," *IEEE Microw. Wireless Compon. Lett.*, vol. 18, no. 6, pp. 383–385, June 2008.
- [22] A. Chinea, P. Triverio, and G. Grivet-Talocia, "Delay-based macromodeling of long interconnects from frequency-domain terminal responses," *IEEE Trans. Adv. Packag.*, Accepted for future publication.
- [23] P. Triverio, S. Grivet-Talocia, and M. S. Nakhla, "A parameterized macromodeling strategy with uniform stability test," *IEEE Trans. Adv. Packag.*, vol. 32, no. 1, pp. 205–215, Feb. 2009.
- [24] R. Chakraborty, A. V. Sathanur, and V. Jandhyala, "Active-passive co-synthesis of multi-gigahertz radio frequency circuits with broadband parametric macromodels of on-chip passives," in *Proc. Intl. Conf. Computer Aided Design*, Nov. 2009, pp. 759–766.
- [25] D. Deschrijver, *Broadband Macromodeling of Linear Systems by Vector Fitting*, PhD dissertation, University of Antwerp, Belgium, 2008.
- [26] P. Triverio, *Self Consistent, Efficient and Parametric Macromodels for High-speed Interconnects Design*, PhD dissertation, Politecnico di Torino, Italy, 2009.
- [27] "Official website of vector fitting," <http://www.energy.sintef.no/produkt/VECTFIT/>.
- [28] "Official website of IdemWorks," <http://www.idemworks.com/>.
- [29] "Official website of MATLAB RF toolbox," <http://www.mathworks.com/products/rftoolbox/>.
- [30] "Official website of Ansoft Nexxim," <http://www.ansoft.com/products/hf/nexxim/>.
- [31] R. Achar and M. S. Nakhla, "Simulation of high-speed interconnects," *Proc. IEEE*, vol. 89, no. 5, pp. 693–728, May 2001.
- [32] R. Kumaresan, "Identification of rational transfer function from frequency response sample," *IEEE Trans. Aerosp. Electron. Syst.*, vol. 26, no. 6, pp. 925–934, Nov. 1990.
- [33] C. Sanathanan and J. Koerner, "Transfer function synthesis as a ratio of two complex polynomials," *IEEE Trans. Autom. Control*, vol. 8, no. 1, pp. 56–58, Jan. 1963.
- [34] K. Steiglitz and L. E. McBride, "A technique for the identification of linear systems," *IEEE Trans. Autom. Control*, vol. 10, no. 4, pp. 461–464, Jan. 1965.
- [35] P. Triverio and S. Grivet-Talocia, "Robust causality characterization via generalized dispersion relations," *IEEE Trans. Adv. Packag.*, vol. 31, no. 3, pp. 579–593, Aug. 2008.
- [36] P. Triverio, S. Grivet-Talocia, M. S. Nakhla, F. Canavero, and R. Achar, "Stability, causality, and passivity in electrical interconnect models," *IEEE Trans. Adv. Packag.*, vol. 30, no. 4, pp. 795–808, Nov. 2007.
- [37] S. Grivet-Talocia and A. Ubolli, "A comparative study of passivity enforcement schemes for linear lumped macromodels," *IEEE Trans. Adv. Packag.*, vol. 31, no. 4, pp. 673–683, Nov. 2008.
- [38] T. Palenius and J. Roos, "Comparison of reduced-order interconnect macromodels for time-domain simulation," *IEEE Trans. Microw. Theory Tech.*, vol. 52, no. 9, pp. 2240–2250, Sept. 2004.