

# Advances in Automobile Engineering: Brake Assisted Differential Locking System

Kanwar Bharat Singh

**Abstract** - "It takes 8,460 bolts to assemble an automobile, and one nut to scatter it all over the road."

Some of the biggest advances in the field of automotive technology in the past 10 years have come in the area of safety. Spurred by the improvements in the microprocessor speed, miniaturization, and software development, the automobile continues to evolve.

In this new approach proposed, I am going to have an electronic and a pneumatic circuit to automatically control the traction of the vehicle.

During ordinary conditions, when the vehicle is driven down a straight road, or if the difference between speeds of the two (rear) wheels is below a specified limit, no signal will be generated by the electronic circuit. This helps the vehicle negotiate the turns with better traction control as differential action is unaltered. But if the difference between speeds is beyond a specified limit, the signal will be generated by the electronic circuit which will actuate the pneumatic circuit. This causes gradual braking on the faster wheel until it gains traction. Hence, the wheels will never lose traction.

This system ensures a reduction of more than 50% in the capital investment as compared to the already existing systems can tilt the scales in the favour of the manufacturing company and eventually the cost conscious consumer

**Keywords** – Differential locking, traction control, Limited slip differential, pneumatic braking.

## I. INTRODUCTION

Are you REALLY comfortable manoeuvring your vehicle through a muddy patch?

In dry conditions, when there is plenty of traction, the amount of torque applied to the wheels is limited by the engine and gearing; in a low traction situation, such as when driving on ice, the amount of torque is limited to the greatest amount that will not cause a wheel to slip under those conditions. So, even though a car may be able to produce more torque, there needs to be enough traction to transmit that torque to the ground. As long as the tyre grips the road, providing a resistance to turning, the drive train forces the vehicle forward.

Manuscript received March 22, 2008. This work was supported in part by the Automotive Research Association of India (ARAI), pune, India. The Author is with Tata Motors Ltd, pune, India, phone: +919250006237 fax: 91 124 2805140 e-mail: Kanwar.singh@tatamotors.com

Driveline torque is evenly distributed between the two rear drive axle shafts by the differential. When one tyre encounters a slippery spot on the road, it loses traction, resistance to rotation drops, and the wheel begins to spin. Because the resistance has dropped, the torque delivered to both the wheels changes. The wheel with good traction is no longer driven. If the vehicle is stationary in this condition, only the wheel over the slippery spot rotates. Hence the vehicle does not move. This situation places stress on differential gears. As the traction fewer wheels rotates at a very high speed, amount of heat generated increases rapidly, lube film breaks down, metal to metal contact occurs, and the parts are damaged. Now if the spinning wheel suddenly has traction, then the shock of the sudden traction can cause severe damage to the drive axle assembly.

So presently how do we overcome these difficulties?

To overcome these problems, differential manufacturers have developed the Limited Slip Differential. In automotive applications, a limited slip differential (LSD) is a modified or derived type of differential gear arrangement that allows for some difference in rotational velocity of the output shafts, but does not allow the difference in speed to increase beyond a preset amount. In an automobile, such limited slip differentials are sometimes used in place of a standard differential, where they convey certain dynamic advantages, at the expense of greater complexity. The main advantage of a limited slip differential is found by considering the case of a standard (or "open") differential where one wheel has no contact with the ground at all. In such a case, the contacting wheel will remain stationary, and the non-contacting wheel will rotate at twice its intended velocity – the torque transmitted will be equal at both wheels, but will not exceed the threshold of torque needed to move the vehicle, thus the vehicle will remain stationary. In everyday use on typical roads, such a situation is very unlikely, and so a normal differential suffices. For more demanding use however, such as driving off-road, or for high performance vehicles, such a state of affairs is undesirable, and the LSD can be employed to deal with it. By limiting the velocity difference between a pair of driven wheels, useful torque can be transmitted as long as there is some friction available on at least one of the wheels. The clutch type LSD responds to drive shaft torque. The more drive shaft input torque present, the harder the clutches are pressed together and thus the more closely the drive wheels are coupled to each other.

Limitations of the Limited Slip Differential

- a) Heat dissipation leads to lube film breakage, metal-to-metal contact occurs.
- b) If the friction lining of the energized clutch is damaged, the whole assembly has to be disassembled.
- c) High quality lubrication required.
- d) Due to presence of large number of mechanical components, reliability is less.
- e) As the speed increases, noise of vehicle also increases.
- f) Complicated and costly.

**II. PROPOSED INNOVATION-BRAKE ASSISTED DIFFERENTIAL LOCKING SYSTEM (BADLS)**

In this new approach, there is an *electronic* and a *pneumatic circuit* to automatically control the traction of the vehicle. During the ordinary conditions, when the vehicle is driven down the straight road, or if the difference between the speeds of the two (rear) wheels is below a specified limit, no signal will be generated by the electronic circuit. This helps the vehicle negotiate the turns with better traction control, as the differential action is unaltered. But if the difference between the speeds is beyond a specified limit, the signal will be generated by the electronic circuit, which will actuate the pneumatic circuit. This causes gradual braking on the faster wheel until it gains traction. Hence, the wheels will never lose traction. The BADLS control module senses that a wheel is about to slip based on the input sensor data and in turn pulses the normally open inlet solenoid valve closed for that circuit. This allows fluid to enter the circuit. At the same time, the control module opens the normally closed solenoid valve for that circuit. This leads to the application of pneumatic pressure on the brake pads, leading to the artificial braking. Once the affected wheel returns to the same speed as the other wheel the control module returns both the valves to their respective normal positions releasing any residual pressure in the pneumatic circuit of the affected brake.

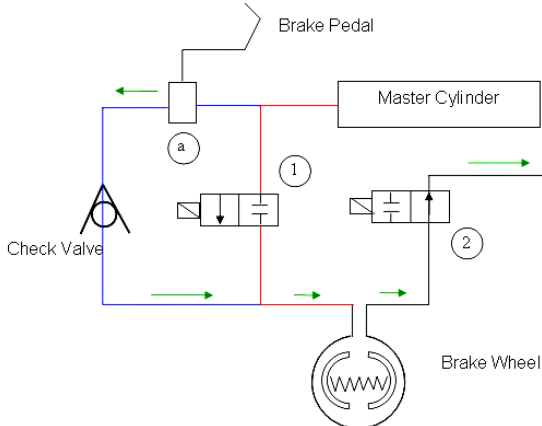

Fig. 1 SCHEMATIC CIRCUIT OF BADLS

**WORKING:**

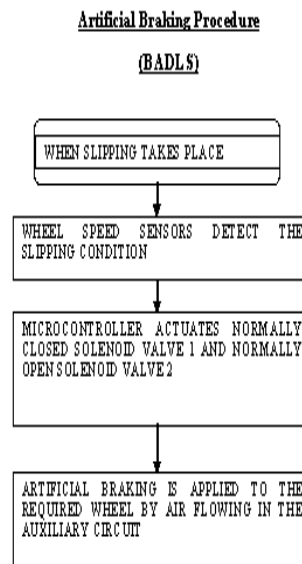
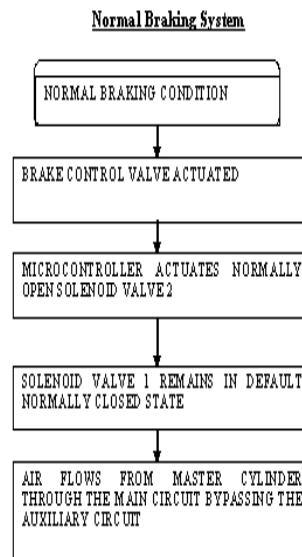

Fig. 2 WORKING OF THE BADLS CIRCUIT

Flowchart to explain working of the circuit shown in Fig 1 is given above in Fig 2 First flowchart shows working of normal braking circuit and the latter shows the working when the badls circuit is working. During normal braking condition solenoid valve 1 is in closed condition so air from master cylinder flows in main braking circuit bypassing the auxiliary circuit through solenoid valve 1 and thus normal braking action is achieved. In slipping condition microcontroller actuates normally closed solenoid valve and normally open solenoid valve 2 and thus artificial braking is applied to the required wheel.

A. The BADLS Control module

The system is provided a control system, at least two driven wheels, a differential for transmitting power from the

engine to the driven wheels and permitting relative velocity between the driven wheels. The control system includes two wheel velocity sensor, a comparator circuit and a control circuit. The wheel velocity sensor is configured to detect the angular velocity of the two driven wheels and to generate a signal. The comparator circuit is coupled to the wheel velocity sensor and is configured to compare the signals of the sensors and to generate a slip signal representative of the degree of slip of the driven wheels. The control circuit is coupled to the comparator circuit and to the brake assisted differential locking mechanism and is configured to generate control signals when a predetermined degree of slip occurs and to apply the control signals to the differential locking mechanism to limit relative velocity between the driven wheels.

### III. PROPOSED ARCHITECTURE FOR BRAKE ASSISTED DIFFERENTIAL LOCKING SYSTEM

The control circuit shown below in Fig.3 is configured to receive signals representative of vehicle operating parameters (condition of slipping of wheels) and to generate control signals corresponding to the desired state of the brake assisted differential locking mechanism for limiting relative velocity between two driven wheels. Sensors are associated with the rear wheels. Control logic executed by the control circuit in a continuously cycled routine determines the desired state of the

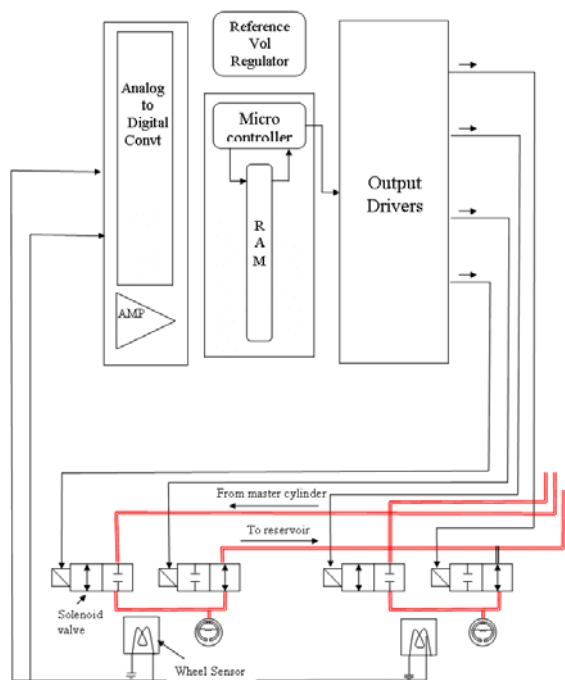

Fig. 3 PROPOSED ARCHITECTURE OF SYSTEM

differential locking mechanism based upon the operating parameters. The control circuit applies an appropriate control signal to the differential locking mechanism causing engagement or disengagement in accordance with the desired

state. Wheel velocity sensor are configured to detect the velocity of the two rear wheels and to generate a wheel velocity signal given as an input to the micro controller. A comparator circuit of the micro controller is coupled to the wheel velocity sensors generate a slip signal representative of the degree of slip of the driven wheel. A control circuit is coupled to the comparator circuit and to the differential locking mechanism and configured to generate control signals when a predetermined degree of slip occurs and to apply the control signals to the differential locking mechanism to limit relative velocity between the driven wheels by applying artificial braking by actuating the solenoid valves. The control circuit is further configured to disengage the differential locking mechanism when the degree of slip decreases to a level below a predetermined threshold. Wheel velocity sensor is provided for each of the driven wheels, each of the wheel velocity sensors being configured to generate wheel velocity signals and to apply the wheel velocity signals to the comparator circuit, and wherein the control circuit is configured to generate control signals for limiting relative velocity between the driven wheels when slip of any driven wheel exceeds a predetermined threshold value.

### IV. SPECIFICATIONS FOR ELECTRONIC COMPONENTS

- MICRO CONTROLLER
- ANALOG TO DIGITAL CONVERTER
- SIGNAL CONDITIONER

1. Transistor
2. Diode

#### A. MICROCONTROLLER

*USE IN BADLS:* The microcontroller input is the speed of the two wheel speed sensors. The microcontroller obtains the difference in between the two speed sensor outputs and compares it with the maximum allowable variation. If the variation is beyond the stipulated value, it activates the solenoid valves, thus enabling the auxiliary circuit, avoiding any slipping of the wheels.

#### B. SOLENOID VALVE

*USE IN BADLS:* They act as ON/OFF switches and control flow of pressurized air into the Auxiliary Circuit. *TYPE:* Spool Type

#### C. ANALOG TO DIGITAL CONVERTER

*USE IN BADLS:* the analog speed signal from the wheel speed sensors is converted into the digital format by the ADC which is supplied as the input to the microcontroller

#### D. AIR BRAKING SYSTEM

In the air brake's simplest form, called the straight air system, compressed air pushes on a piston in a cylinder. The piston is connected to a brake shoe, which can rub on the wheel, using the resulting friction to slow the train. The pressurized air comes from an air compressor and is circulated by a pneumatic line made up of pipes and hoses. In order to apply the braking force to the brake shoes, compressed air is used. An air brake system in general includes a compressor unit, air-reservoir tank, brake chamber and wheel mechanism. For maintaining adequate braking force at all times even when the engine is not running and air-reservoir tank is also necessary. To maintain air pressure, which is small air pump, is used.

The compressor takes air from the atmosphere through the filter and the compressor air is sent to the reservoir through the unloader valve, which gets lifted at a predetermined reservoir pressure and relieves the compressor load. From the reservoir the air goes to the various accessories and also to the brake chambers also called the diaphragm units at each wheel, through the brake valve. The control of brake valve is with the driver who can control the intensity of braking according to the requirements. The unloader valve in the air breaking system serves to regulate the line pressure

#### V. TESTING AND EVALUATION PARAMETERS

The system has been tested on a SAE BAJA test vehicle at the Automotive Research Association of India (ARAI), pune. This was done keeping in mind that this application would be really helpful for SAE BAJA teams who encounter conditions like slipping of wheels very often. Since vehicle slip is usually about 12-15% while turning, this microcontroller of the system has been designed to active at about 20% slip conditions and deactivates at about 5% slip. The system was tested successfully and the next step would be practical implementation in automobiles after some minor modification. The vehicle was jacked up on one wheel with the other wheel resting on ground surface. This was done to simulate the condition of maximum slipping. This condition will be present in actual conditions when vehicle is negotiating rocky terrain. The engine was started and accelerated. Due to one wheel being in air, the vehicle did not move forward and the jacked wheel rotated excessively. Now the solenoid was activated for the slipping wheel and artificial braking was provided. As a result the torque transmitting capacity of the wheels increases and consequently, the vehicle pulls over the rocks and gravel on the basis of the torque from the individual wheel.

#### VI. COST COMPARISON TABLE

As can be seen from the above table that this system ensures a reduction of more than 50% in the capital investment as compared to the already existing systems.

Table I. COMPARISON OF BADLS SYSTEM WITH EXISTING LSD SYSTEM IN THE MARKET

EXISTING SYSTEM		PROPOSED SYSTEM	
1. LIMITED DIFFERENTIAL (LSD)	SLIP	1. OPEN DIFFERENTIAL	: Rs. 20,000/-
		2. ELECTRONIC CIRCUIT	: Rs. 1000/-
		3. SPEED SENSORS (Nos.2)	: Rs. 7500/-
		4. CHECK VALVE (Nos.2)	: Rs. 1000/-
		5. SOLENOID VALVE (Nos.4)	: Rs. 1000/-
• TRD LSD	Rs. 60000		
• QUAIFFE LSD	Rs. 70000		
<b>TOTAL-RS 65000 or \$1625</b>		<b>TOTAL-RS 31000 or \$750</b>	

#### VII. ADVANTAGES

- Can be easily implemented in vehicles having pneumatic braking systems with slight modification.
- As electronic circuitry is used, response time, control and reliability are better than the existing systems.
- Low grade lubricants can be used as heat loss is reduced.
- Last but not the least; the system is economical and simple.

#### VIII. LIMITATIONS

The overall efficiency depends on the combined efficiency of both the electronic as well as the pneumatic system.

#### IX. APPLICATIONS

The system can be successfully incorporated in vehicles having pneumatic/hydraulic braking system, with a view to provide improves traction. It can be put to use in especially All Terrain Vehicles (ATV) and vehicles operating in high altitude areas (vehicles for military application) where snow causes excessive loss of traction. This system ensures a reduction of more than 50% in the capital investment as compared to the already existing systems which ensures the cost effectiveness of the endeavour.

#### ACKNOWLEDGMENTS

The author is grateful to Prof. R.B.Patil, Head of Department, Army Institute of technology, India and Dr KC Vora at the Automotive Research Association of India, (ARAI) for their guidance and support.

#### REFERENCES

- Jack Erjavec, Automotive Technology- A systems approach (Delmar Thomson Learning, 2000)
- T.K. Garrett, K.Newton, W.Steeds, the Motor Vehicle (Butterworth Heinmann, 2001)