

# Heat Transfer Simulation by CFD from Fins of an Air Cooled Motorcycle Engine under Varying Climatic Conditions

Pulkit Agarwal, Mayur Shrikhande and P. Srinivasan

**Abstract** — An air-cooled motorcycle engine releases heat to the atmosphere through the mode of forced convection. To facilitate this, fins are provided on the outer surface of the cylinder. The heat transfer rate depends upon the velocity of the vehicle, fin geometry and the ambient temperature. Many experimental methods are available in literature to analyze the effect of these factors on the heat transfer rate. However, an attempt is made to simulate the heat transfer using CFD analysis. The heat transfer surface of the engine is modeled in GAMBIT and simulated in FLUENT software. An expression of average fin surface heat transfer coefficient in terms of wind velocity is obtained. It is observed that when the ambient temperature reduces to a very low value, it results in overcooling and poor efficiency of the engine.

**Index Terms** — Simulation, Computational Fluid Dynamics (CFD), Heat Transfer, Fins.

## I. INTRODUCTION

Since long time, there has been a progressive demand for high efficiency and high specific power output engines. This necessitates a detailed study of engine subsystems of which cooling system is also an important component. Air cooled motorcycle engines release heat to the atmosphere through forced convection. The rate of heat transfer depends upon the wind velocity, geometry of engine surface, external surface area and the ambient temperature. Motorbikes engines are normally designed for operating at a particular atmospheric temperature. There is an optimal cooling rate of an engine for its efficient operation. If the cooling rate decreases, it results in overheating leading to seizure of the engine. At the same time, an increase in cooling rate affects the starting of the engine and reduces efficiency.

A number of experimental studies have been done on cooling of air-cooled engine fins [1]-[7]. Air cooled

cylinders were tested at wind velocities from 7.2 to 72 km/hr to design fins for motorcycle engines and an experimental equation for the following fin surface heat transfer coefficient was derived [1].

$$\alpha = 2.11u^{0.71} \times s^{0.44} \times h^{-0.14} \quad (1)$$

where

$\alpha$ : Fin surface heat transfer coefficient[W/m<sup>2</sup> °C],h: Fin length [mm],u: Wind velocity[km/hr], s: fin separation at middle length[mm]

Gibson [2] conducted experiments on cylinder cooling at relatively high velocities and derived an experimental equation for the fin surface heat transfer coefficient as follows:

$$\alpha = 241.7\{0.0247-0.00148(h^{0.8}/p^{0.4})\} u^{0.73} \quad (2)$$

where

$\alpha$  : Fin surface heat transfer coefficient[W/m<sup>2</sup> °C],h: Fin length[mm],p: Fin pitch[mm],u: Wind velocity[km/hr]

TABLE I  
EXPERIMENTAL CYLINDER AND WIND VELOCITY BY THORNHILL ET AL. [1], GIBSON [2] AND BIERMAN ET AL.[3]

	Thornhill et al. [1]	Gibson [2]	Bierman et al. [3]
Cylinder Diameter[mm]	100	32-95	118.364
Fin Pitch [mm]	8-14	4-19	1.448-15.240
Fin Length mm]	10-50	16-41	9.398-37.338
Material	Aluminium alloy	Copper, Steel, Aluminium	Steel
Wind Velocity [km/hr]	7.2-72	32-97	46.8-241.2

Experiments on a finned cylinder were conducted and optimization of the number of fins and fin pitch in air cooling was done [4].

Following experimental equation for the fin surface heat transfer coefficient was derived [4].

$$\alpha_{avg} = (2.47-2.55/p^{0.4}) \times u^{0.9} \times 0.0872p+4.31 \quad (3)$$

where

$\alpha_{avg}$  : Fin surface heat transfer coefficient[W/m<sup>2</sup> °C],p:Fin pitch[mm],u: Wind velocity[km/hr]

These equations are instrumental in calculating average fin surface heat transfer coefficient for finned cylinders with varied designs.

Even though a large number of heat transfer simulations

Manuscript received on February 28, 2011.

(a) Pulkit Agarwal is an undergraduate student pursuing B.E. Mechanical Engineering from Birla Institute of Technology and Science, Pilani, Rajasthan - 333031, India. (Corresponding Author. Phone: 091-11-25220836, e-mail: pulkit2k7@gmail.com)

(b) Mayur Shrikhande is an undergraduate student pursuing B.E Mechanical Engineering from Birla Institute of Technology and Science, Pilani, Rajasthan-333031, India.(e-mail: mayur.shrikhande@gmail.com)

(c) Dr P. Srinivasan is presently Assistant Professor in Mechanical Engineering Department of Birla Institute of Technology and Science, Pilani, Rajasthan-333031, India.(e-mail: srinibits@gmail.com)

have been performed, not many attempts have been made to study the effect of climatic conditions on heat transfer rate from fin surface of air cooled engines in motorbikes. The heat transfer from a fin is influenced by many fixed and variable parameters such as air flow velocity, temperature, heat flux at cylinder wall, fin geometry size, shape, material etc. In this study, CFD has been used for analyzing the similar model of engine as used in [4]. The effect of the wind velocity and surrounding air temperature was studied in detail by modeling the motorcycle engine as a finned cylinder and simulating through the commercially available CFD code FLUENT at velocities from 40 to 72 km/hr which is the most common operating range of motorcycles. The remaining parameters namely fin geometry, heat flux at cylinder wall, material were kept fixed. An attempt has been made to derive an equation for average fin surface heat transfer coefficient for the same engine model in terms of wind velocity and to calculate the extra amount of fuel consumed due to the overcooling process.

## II. METHODOLOGY

### A. Modeling and Design

The engine was modeled as an aluminium cylinder with fins on its outer surface and a stroke volume of 150 to 187 cm<sup>3</sup> as shown in Fig. 1. The model was created in GAMBIT software which is also used as a pre-processor for meshing and boundary zone definitions.

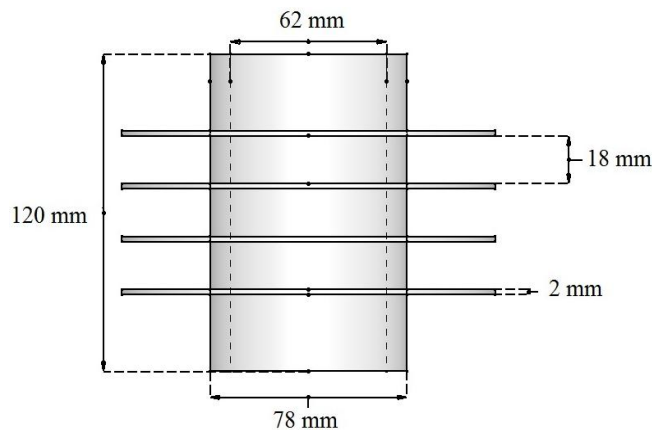

Fig. 1: Cylinder modeled for simulation (with dimensions).

The computational domain consists of a rectangular volume of large dimensions containing the finned cylinder at its centre. It was focused on the fins and appropriate boundary conditions were applied at the domain ends to maintain continuity. The domain was made longer after the cylinder to allow for wake formation.

A fine mesh has been created near the fins to resolve the thermal boundary layer which is surrounded by a coarse external mesh for better results and fast solution. A face mesh has been done by quad element and pave scheme with size function as shown in Fig.2. The volume was then meshed by hex element and cooper scheme in GAMBIT to obtain the 3D mesh. The metallic fins have also been

meshed using the same principles for obtaining accurate temperature distribution.

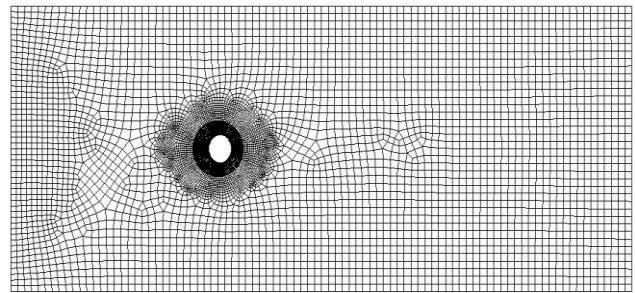

Fig. 2: Top view of the 3D Grid for flow across finned cylinder.

### B. Mathematical model

The solver in FLUENT works on Finite Volume Method (FVM) and in this case solved the standard Navier - Stokes equations of fluid flow in three dimensions for finding the pressure and velocity at domain points. SIMPLE method for pressure velocity coupling was implemented for pressure correction. The following momentum conservation was used along with the continuity equation:

$$\frac{\partial(\rho v)}{\partial t} + v \nabla \cdot (\rho v) = -\nabla P + \nabla \cdot \tau + F + \rho g \quad (4)$$

For modeling heat transfer, the energy equation is solved in the following form:

$$\frac{\partial(\rho E)}{\partial t} + \nabla \cdot (v(\rho E + p)) = \nabla \cdot (k_{eff} \nabla T - \sum_j h_j J_j + (\tau \cdot v)) + S_h \quad (5)$$

Eq. 5 is used to solve for temperature at different points in the fluid region. The 3D differential equation can be solved as a scalar transport equation to calculate the temperature at the fin surface and cylinder surface for which the above equation reduces to the following:

$$\nabla^2 T + \dot{q}/k = 1/\alpha \frac{\partial T}{\partial t} \quad (6)$$

In this case  $\dot{q} = 0$  as there is no internal heat generation in cylinder wall. Also  $\frac{\partial T}{\partial t} = 0$  owing to steady state assumption.

Closure in turbulence was obtained by using the Spalart-Allmaras model which is best suited for external flows. It is a one equation model solved for turbulent kinematic viscosity.

### C. Problem setup in Fluent

The flow around the finned cylinder has been solved at different airflow velocities from 20 km/hr to 72km/hr, and at air temperatures ranging from -10°C to 30°C.

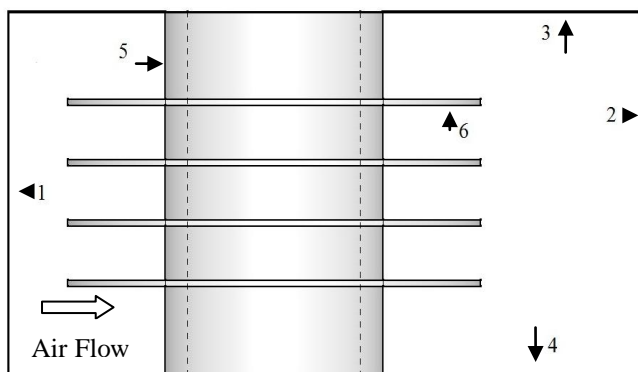

Fig. 3: Boundary Conditions for the given problem.

Fig. 3 shows the appropriate boundary conditions used to solve for heat flow through the cylinder. Boundary conditions applied at the domain ends helped in maintaining continuity.

1. Inlet face (1) was given fixed velocity condition. The velocity and temperature of the entering air was chosen depending upon the case being solved.
2. Outlet face (2) was given fixed pressure condition of 101.325kPa representing atmospheric pressure.
3. Top and bottom faces (3, 4) faces were specified as adiabatic walls and the flow is kept from left to right.
4. The outer curved surface of the cylinder (5) was given the wall boundary condition. Temperature was specified at the inner surface of hollow cylinder giving specified thickness.
5. The body of metallic fin (6) was meshed and specified as solid region. Henceforth, it is solved by heat conduction equation.

A three dimensional steady state conjugate heat transfer analysis has been done by assuming a constant temperature on the inner surface of the cylinder wall and evaluating the quantity of heat lost from the engine surface which is modeled as a finned cylinder. The temperature at the inner wall of cylinder surface is assumed constant at 150 °C to account for heat generated due to combustion inside the engine.

For obtaining the relation between heat transfer coefficient and velocity, the temperature was maintained constant and the simulations were carried out varying the velocity from 40km/hr to 72 km/hr. The values of heat transfer coefficient were directly proportional to wind velocity specified for the simulation. Similar values of heat transfer coefficient were obtained for different temperatures verifying the independence of heat transfer coefficient on atmospheric temperature.

To calculate the extra fuel consumed due to overcooling, simulations were carried out and the heat transfer rate was found at different temperatures ranging from -10 °C to 27 °C keeping a fixed velocity. This extra fuel consumption was calculated for different velocities.

### III. RESULTS AND DISCUSSION

#### A. Flow Pattern on fin

The flow pattern on the fin surface at wind velocity of 60km/hr is shown in Fig. 4. Flow separation occurs resulting in wake formation on leeward side. This is indicated by blue vectors representing very low velocity.

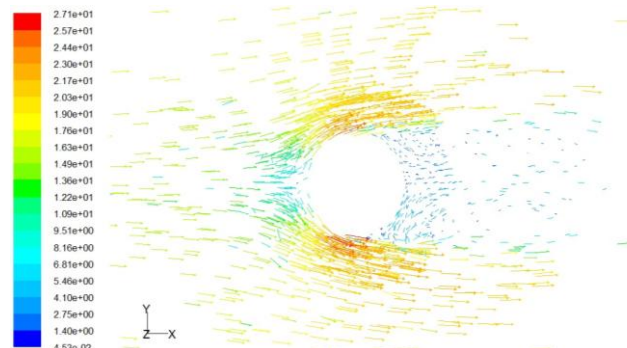

Fig. 4: Velocity vector plot for fin surface at velocity 60 km/hr.

#### B. Temperature distribution across the fins

The temperature distribution on the metal fins was obtained at different conditions are shown below. Fig. 5 displays filled contours of temperature variation of fin surface in the 3D grid.

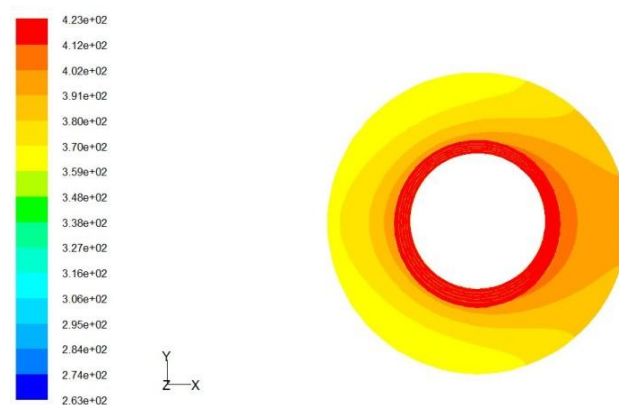

Fig. 5(a): Contour plots of temperature (K) on fins at wind velocity 60 km/hr and temperature -10°C.

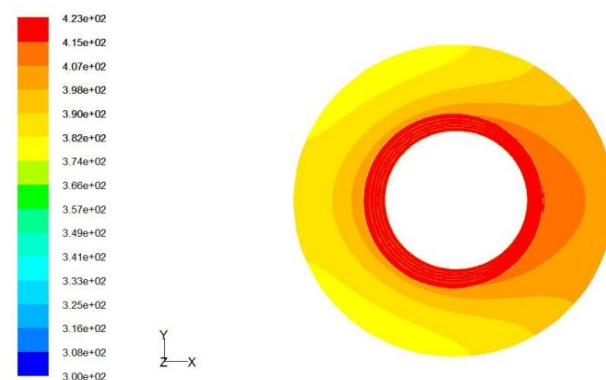

Fig. 5(b): Contour plots of temperature (K) on fins at wind velocity 60 km/hr and temperature 27°C.

The figure shows variation of surface temperature along the fin surface. The wind is modeled to flow towards right and the area on the fin after the cylinder receives air at low velocity being the region of wake formation. Consequently, heat loss by forced convection is reduced and the surface temperature in this region is higher than that on the front side. Moreover, a comparison between the two figures indicates an increase in temperature on the fin surface with increasing atmospheric temperature which results from decrease in heat transfer due to less temperature gradient. This demonstrates the overcooling effect in regions of sub-zero temperatures and hence necessitates the need for this study.

C. Heat transfer coefficient of the fin surface

The convection heat transfer from fin surface to atmosphere air by forced air is given as:

$$Q = hA(T_{avg} - T_{air}) \tag{7}$$

where

Q: Heat flux from fin surface, h: Fin surface heat transfer coefficient, A: Surface area of fin,  $T_{avg}$ : Average fin surface temperature,  $T_{air}$ : Atmospheric temperature

At different wind velocities and air temperatures, the average heat flux was calculated for each of the fins. Using this data and the average fin temperature, the average fin surface heat transfer coefficient was calculated for each case. The values of heat transfer coefficients obtained at different velocity conditions verified to a very good agreement with [3]. Thus a correct benchmark for investigating the effect of velocity and temperature was obtained through CFD simulation.

A mathematical relation of the average surface heat transfer coefficient in terms of wind velocity was formulated by using the empirical relation:

$$Nu = C (Re)^m (Pr)^n \tag{8}$$

where

Nu: Nusselt number, Re: Reynolds number and Pr: Prandtl number.

The values of heat flux through the fin surface and wind velocity were used to solve the empirical equation. At velocities of 40km/hr, 60km/hr and 72km/hr the heat transfer coefficients were computed from the heat flux values of 724W, 933.56W and 1123.03W respectively. Using these values and neglecting the variation of viscosity, density and specific heat with temperature, the unknown variables in Eq. 8 were solved at each temperature. Subsequent operations by averaging out these unknowns resulted in the following relation:

$$h = 5.108 u^{0.643} \tag{9}$$

where

h: Average fin surface heat transfer coefficient, u: wind velocity in km/hr.

With the heat transfer coefficient being independent of the ambient temperature, Eq. 9 relates the heat transfer coefficient with the wind velocity at all atmospheric temperatures for the geometry shown in Fig. 1.

Fig. 6 shows the comparison of the above equation obtained in this study with those obtained by [1] and [4].

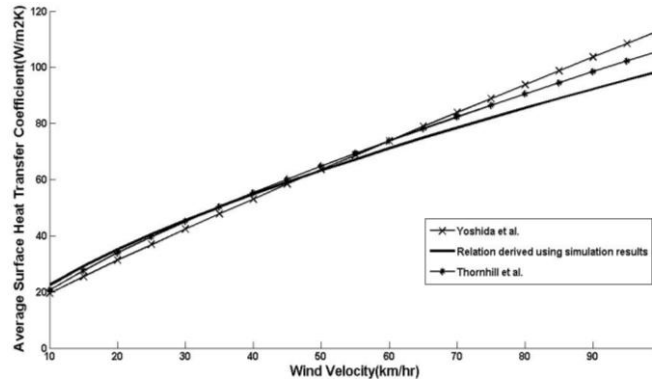

Fig. 6: Plot of heat transfer coefficient vs. wind velocity.

The closeness of the graphs reassures the correctness of the simulation. The small deviation between the graphs can be accounted to experimental errors and approximations used in simulation.

D. Heat loss from the engine

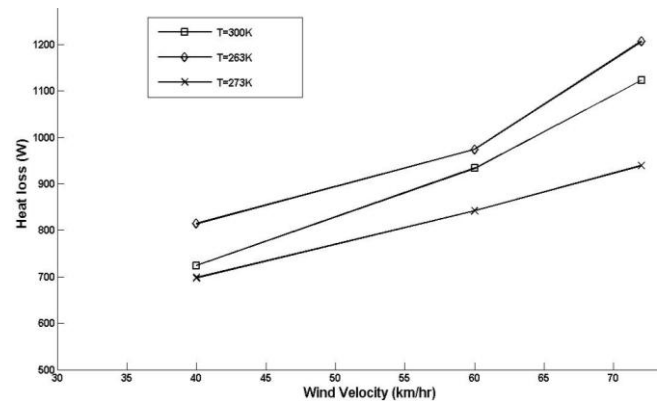

Fig. 7: Plot of Rate of heat loss vs. Wind velocity at different operating conditions.

Fig. 7 shows that the heat lost at same vehicle speed increases with decrease in atmospheric temperature. Also, with temperature remaining constant, the heat transfer coefficient increases with velocity leading to increased heat transfer. An excess heat loss from the engine surface is undesirable as it results in decreased efficiency and excess fuel consumption. Hence, wind velocity has to be reduced for conserving fuel.

Following relation is employed to calculate the excess fuel consumed due to overcooling of the engine:

$$\Delta m \times CV = \Delta Q \tag{10}$$

where

$\Delta m$ : Extra fuel consumption, CV: Calorific value of the fuel,  $\Delta Q$ : Difference of heat flux values at two different temperatures and at same vehicle speeds.

It was seen from the results obtained that the difference in heat lost at  $-10^{\circ}C$  and  $27^{\circ}C$  was around 132.26W at 60km/hr (This particular speed has been chosen as it lies in the middle of range of speeds). The extra heat lost due to the change in surrounding temperature was then related to the loss of fuel and it was found that the extra fuel burnt was around 9.93 gm/hr implying a significant amount of fuel wasted.

## REFERENCES

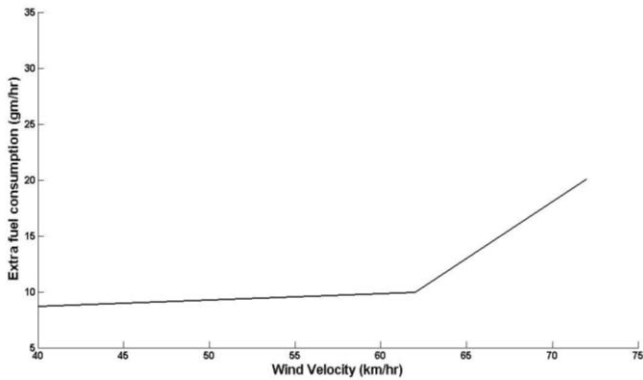

Fig. 8: Plot of extra fuel consumed due to overcooling with wind velocity at temperatures of  $-10^{\circ}\text{C}$  and  $27^{\circ}\text{C}$ .

Fig. 8 indicates that an increase in wind velocity results in increase in excess fuel consumption due to overcooling. This variation increases steeply at velocities more than 60km/hr.

This necessitates the need of reducing the air velocity striking the engine surface to reduce the fuel consumption. It can be done by placing a diffuser in front of the engine which will reduce the relative velocity of the air stream thus decreasing the heat loss.

## IV. CONCLUSION

A brief summary of the work completed and significant conclusions derived from this work are highlighted below.

1. A model for an air cooled motorcycle engine was developed and effects of wind velocity and air temperature were investigated. The paper confirms the results of the experimental study of heat transfer dependence on different stream velocities. An analysis of heat transfer under different surrounding temperatures has also been carried out to reduce the overcooling of engines.
2. The temperature and heat transfer coefficient values from fin base to tip are not uniform which shows the major advantage of CFD for analysis of heat transfer.
3. The extra heat loss which takes place in the regions of subzero temperature has been found out. Using this data, the amount of fuel conserved can be easily calculated.
4. A method of preventing this excessive heat loss is to use a diffuser in the path of air before it strikes the engine surface. This will help in reducing the air velocity and help in improving the efficiency of the engine.

- [1] D. Thornhill D, A. Graham, G. Cunningham, P. Troxier and R. Meyer, "Experimental Investigation into the Free Air-Cooling of Air-Cooled Cylinders", *SAE Paper* 2003-32-0034, (2003).
- [2] A. H Gibson, "The Air Cooling of Petrol Engines", *Proceedings of the Institute of Automobile Engineers*, Vol.XIV (1920), pp.243-275.
- [3] A. E Biermann and B. Pinkel, "Heat Transfer from Finned Metal Cylinders in an Air Stream", *NACA Report* No.488 (1935).
- [4] Masao Yoshida, Soichi Ishihara, Yoshio Murakami, Kohei Nakashima, and Masago Yamamoto, "Air-Cooling Effects of Fins on Motorcycle Engine", *JSME International Journal*, Series B, Vol.49, No.3 (2006)
- [5] D. Thornhill and A. May, "An Experimental Investigation into the Cooling of Finned Metal Cylinders in a free Air Stream", *SAE Paper* 1999-01-3307, (1999).
- [6] Zakhirhusen K. Memon, T.Sundararajan, V. Lakshminarasimhan, Y.R. Babu and Vinay Harne, "Parametric study of finned heat transfer for Air Cooled Motorcycle Engine", *SAE Paper*, 2005-26-361, (2005).
- [7] A. Nabemoto, "Heat Transfer on a Fin of Fin Tube, Bulletin of the Faculty of Engineering", Hiroshima University, (in Japanese), Vol. 33, No.2 (1985), pp.127-136.