

# Simulation and Analysis of Ventilation Flow Through a Room Caused by a Two-sided Windcatcher Using a LES Method

Amirreza Niktash and B. Phuoc Huynh

**Abstract—** A windcatcher is a structure fitted on the roof of a building for providing natural ventilation using wind power; it exhausts the inside stale air to the outside and supplies the outside fresh air into the building interior space working by pressure difference between outside and inside of the building and using two fundamental natural ventilation principles; namely the stacks effects and the wind driven ventilation. In this paper, air flow through a three-dimensional room fitted with a two-sided windcatcher is observed numerically, using a commercial computational fluid dynamics (CFD) software package.

In this simulation, the optimized model in RANS (Reynolds Averaged Navier-Stokes) method and the standard two-equation K- $\epsilon$  turbulence model has been simulated by using LES (Large Eddy Simulation) CFD technique which is more accurate than RANS method and the results have been analyzed and compared with the obtained results from RANS technique for the optimized model among other models with various windcatcher's bottom shapes, various windcatcher's positions, various inlet velocities, and various windcatcher's bottom lengths.

The achieved results from LES method verify that the two-canal centred position windcatcher with the bottom length of 10 cm provides full circulation for most part of the room and large region of stable velocity in the acceptable range of indoor air speed for human comfort.

**Index Terms—** air flow, CFD, K- $\epsilon$ , LES, windcatcher

## I. INTRODUCTION

NATURAL ventilation has been known as one of the effective methods to provide healthy and comfortable interior environment by preventing moisture development in the air and reducing pollutants concentration effectively. Windcatcher is one of the green features for providing natural ventilation using the free driving force of wind power which has been employed over centuries in the hot arid regions of the Persian Gulf countries called as Baud-Geer and north African countries called as Malqaf.

Malqaf is a bidirectional windcatcher which is mounted on the top of a covered court yard (Fig. 1). Malqaf is normally combined with another architectural element known as Salasabil which is a wavy marble plate that is linked to a source of water [1].

Baud-Geer, on the other hand, is not only bidirectional and has diverse forms and various shapes but also they are used during summers and are closed during winters (Fig. 2). The cross sections of all windcatchers which have circular or squared shapes are divided internally into various segments to get one-sided, two-sided, three-sided, four-sided, hexahedral, and octahedral windcatchers [2], [3].

The low cost of windcatcher system (operational and maintenance cost) in comparison with mechanical ventilation system, being noiseless, durability, requiring no fossil energy, supplying clean air and using sustainable energy of wind have led to use of the windcatcher today as a passive and environmental friendly system.

The experimental studies of windcatcher systems for all different cases are obviously expensive or even impossible. Using computational fluid dynamics (CFD) for flow analysis in the buildings equipped with a windcatcher has become a creditable and reliable tool with reasonable accuracy [4], [5].

In this paper, the optimized model of windcatcher which had been obtained from using RANS K- $\epsilon$  CFD technique is simulated by applying LES CFD method and its results are compared with the achieved results from RANS K- $\epsilon$  method [6]. A commercial CFD software known as CFD-ACE+ by ESI group is employed through the simulation.

## II. MODELLING AND COMPUTATION

According to a previous numerical study and simulation which has been done by the same authors using the standard RANS K- $\epsilon$  method [6], various windcatcher models have been studied. Table I shows the design configurations of the windcatcher model which have been simulated by CFD-ACE+ software using RANS K- $\epsilon$  method.

The study has resulted in the two-canal centred position windcatcher with the bottom length of 10 cm as the optimized two-sided windcatcher among the models with various windcatcher's location, windcatcher's bottom shape and windcatcher's bottom length with the inlet velocity of 3 m/s.

Since LES method is very much time consuming due to its time-dependent flow calculations [7], only the optimized two-sided windcatcher that had been chosen via

Manuscript received November 28, 2013; revised January 9, 2014.

Amirreza Niktash is a Phd student in school of Electrical, Mechanical and Mechatronic Systems of University of technology, Sydney(UTS), Australia(phone: +61-401-172-030; e-mail: Amirreza.Niktash@uts.edu.au).

B. Phuoc Huynh is a senior lecturer in the faculty of engineering and IT of University of technology, Sydney (UTS), Australia (e-mail: Phuoc.Huynh@uts.edu.au).

RANS K- $\epsilon$  CFD method is simulated by using LES CFD method.

Fig. 3 shows the optimized two-sided windcatcher model in a three dimensional room with the length of 5m, the width of 4m, and the height of 3m; it is assumed that wind blows from right to left.

In this model, the outdoor part of windcatcher's height has been assumed to be 2 m and height of indoor part is 90cm with the cross sectional area of 80×80 cm<sup>2</sup>; length of the windcatcher at its bottom (vertical distance from the roof to the windcatcher's canal) is considered as 10 cm ( Fig. 4).

In the present simulation, unstructured triangle meshes have been used throughout the model due to obtain better accuracy in CFD simulation.

To save on computational efforts and reduced accumulated errors, mesh distribution is less dense in regions of expected near stagnant flow like the room corners.

On the other hand, dense mesh has been used in the living area which is far from the corners of the room (Fig. 5).

A grid-independence study has been done for different grid numbers in the model to make sure that the grid pattern used is adequate.

Consequently, the total number of grids in the model is around 186,000 and the maximum and the minimum grid areas are about  $2 \times 10^{-2}$  m<sup>2</sup> and  $1 \times 10^{-4}$  m<sup>2</sup>, respectively.

LES or "Large Eddy Simulation" is a simulation that directly solves the large scale motion but approximates the small scale motion.

LES requires a flow field where only the large scale components are present; this can be achieved via a filtering process. Within the finite volume method, it is rather sensible and natural to define the filter width as an average of the grid volume.

The flow eddies larger than the filter width are large eddies while eddies smaller than the filter width are small eddies which require modeling. When filtering is performed on the incompressible Navier-Stocks equations, a set of equations very similar to the RANS equations are obtained.

Similar to the RANS methods[1], there are additional terms where a modeling approximation must be introduced in LES method. In the context of LES, these terms are the sub-grid scale turbulent stresses which require sub-grid scale (SGS) models to close the set of governing equations.

For the unsolved subgrid scale turbulent stresses, these are modeled accordingly as:

$$\tau_{ij} - \frac{\delta_{ij}}{3} \tau_{kk} = -2\vartheta_T^{SGS} \bar{S}_{ij} \quad (1)$$

$$\bar{S}_{ij} = \frac{\partial \bar{u}_i}{\partial x_j} + \frac{\partial \bar{u}_j}{\partial x_i} \quad (2)$$

Where  $\vartheta_T^{SGS}$  is the subgrid scale kinematic viscosity and  $\bar{S}_{ij}$  is the strain rate of the large scale or resolved field.

The form of the subgrid scale eddy viscosity  $\mu_T^{SGS}$  noting that  $\vartheta_T^{SGS} = \mu_T^{SGS}/\rho$  can be derived by dimensional arguments and is given by:

$$\mu_T^{SGS} = C_s^2 \rho \Delta^2 |\bar{S}_{ij}| \quad (3)$$

$$|\bar{S}_{ij}| = \sqrt{2 \bar{S}_{ij} \bar{S}_{ij}} \quad (4)$$

Where  $\Delta$  is denoted by the grid filter width and the model constant  $C_s$  varies between 0.0065 and 0.3 depending on the particular fluid flow problem[8]. In this work, Smagorinsky

SGS model is applied and the averaged value is assumed for  $C_s$  which is 0.15325.

### III. RESULTS AND DISCUSSION

Uniform and stable air flow velocity in the occupied zone ( the lower part of a room to a height 2m) and full circulation across the room are two important human comfort factors for having proper indoor ventilation.

Fig. 6 shows velocity magnitude along the room at level 1.2m above the floor for the model (two-canal centred position windcatcher with the bottom length of 10 cm ) by using LES method.

It is seen that the velocity magnitude at the level 1.2 m above the floor is approximately stable in the range of 0.48~0.52 m/s across the room at the distance of 1.1m to 4.8 m from the right wall which is about 3.7m of 5 m as the total length of the room (74% of the room's length); consequently, the model provides the uniform flow and results in the most region of the room having velocity in the acceptable range for human comfort; this helps have smooth and less turbulence air flow in the room and confirms the result achieved by using RANS K- $\epsilon$  method.

The flow path traces of the model are shown in Fig. 7; according to the figure, it is seen that the model provides the room with the uniform flow distribution and a full and uniform circulation while there is small stagnation area. The round shape of the canals leads to this uniform flow circulation and distribution in the room which verifies the RANS K- $\epsilon$  method's results as well.

Fig. 8 compares the velocity magnitudes at level 1.2 m above the floor which has been achieved via RANS K- $\epsilon$  method for the two-canal centred position windcatcher with the bottom length of 10cm [1] and the one obtained by LES method.

As it is seen from the graphs, there are only small differences in calculated velocity magnitude via these two computational methods while the trends of velocity changes are very similar to each other. The average difference percentage of the two methods' results is about 4.43%.

### IV. CONCLUSION

As a result, LES method is a reliable and accurate technique for simulation and analyzing the ventilation flow thorough a room fitted by a windcatcher.

The simulation by LES confirms that two-canal centred position windcatcher with the bottom length of 10 cm provides full circulation for most part of the room and large region of stable velocity magnitude in the acceptable range of indoor air velocity for human comfort.

RANS K- $\epsilon$  method is a useful method and good alternative for more accurate simulation methods such as LES where high accuracy is not required .

V. FIGURES AND TABLES



Fig. 1. A typical Malqaf



Fig. 2. A typical Badgir

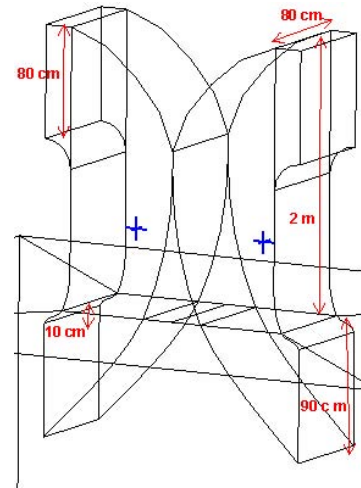

Fig. 4. The optimized two-sided windcatcher

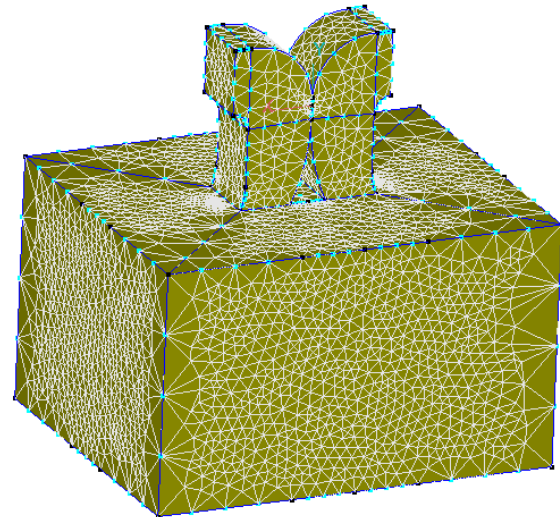

Fig. 5. Unstructured triangle meshes in the model

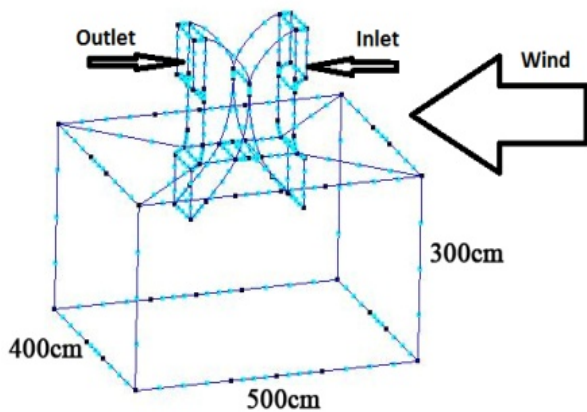

Fig. 3. A 3D modelled room fitted with a windcatcher

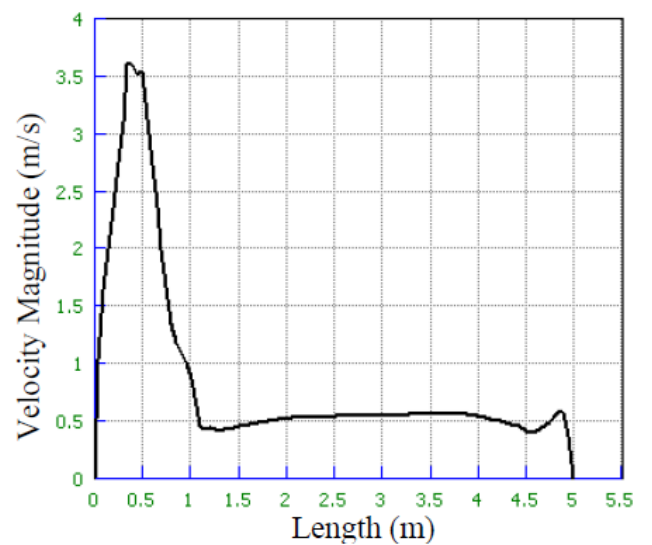

Fig. 6. Velocity Magnitude for 10 cm two-canal centred position windcatcher along the room at level 1.2 m by using LES method

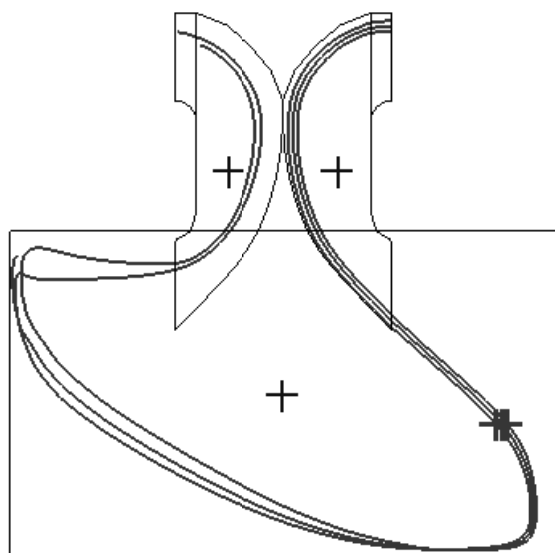

Fig. 7. Some traces of flow path corresponding to the model with 10cm bottom length with inlet velocity of 3 m/s by using LES method

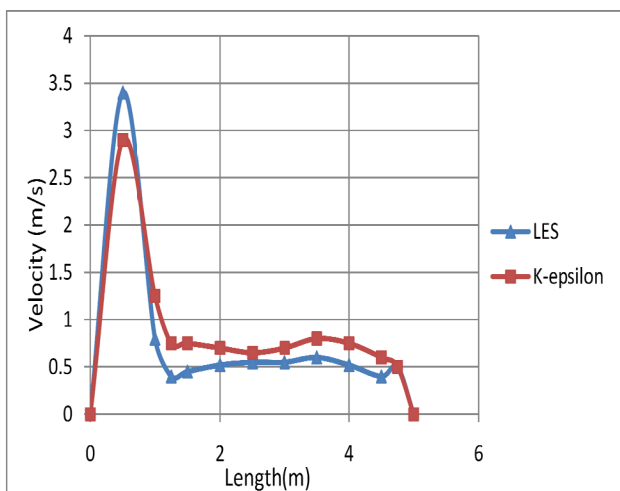

Fig. 8. Comparing the calculated velocities in LES and K-epsilon methods for 10cm bottom length two-canal centred position two-sided windcatcher

Table I  
Design configurations of windcatcher models in  
RANS K-ε method

Configuration	Categories	Variations
1	Windcatcher's Location	Central
2		Right-Sided
3		Left-Sided
4		Front
5		Back
6	Windcatcher's Bottom Shape	Two-Rod
7		Flat
8		Two-Canal
9	Windcatcher's Bottom Length	10 cm
10		20 cm
11		40 cm
12	Windcatcher's Inlet Velocity	0.5 m/s
13		1 m/s
14		3 m/s
15		4.5 m/s
16		6 m/s

#### REFERENCES

- [1] A.M. El-Shorbagy, "Design with nature: windcatcher as a paradigm of natural ventilation device in buildings" in *International Journal of Civil & Environmental Engineering*, vol 10, 2009.
- [2] AA. Elmualim and HB. Awbi, "Wind tunnel and CFD investigation of the performance of windcatcher ventilation systems", *International Journal of Ventilation*, vol 1, no1, 2002, pp 53-64.
- [3] M.N. Bahadori, "Viability of Wind Towers in Achieving Summer Comfort in the Hot Arid Regions of the Middle-East" in *Renewable Energy*, vol 5, no5, 1994, pp 879-892.
- [4] C. Karakatsanis, MN. Bahadori and BJ. Vickery, "Evaluation of pressure coefficients and estimation of air flow rates in buildings employing wind towers" in *Solar Energy*, vol 37, 1986, pp 363-374.
- [5] A.A. Elmualim, "Dynamic modelling of a windcatcher/tower turret for natural ventilation" in *Building Service Engineering Research Technology*, vol 27, no 3, 2006, pp 165-182.
- [6] A.R. Niktash and B.P. Huynh, "Numerical Analysis of Ventilation Flow Through a Three Dimensional Room Fitted with a Two-sided Windcatcher" in *18<sup>th</sup> Australasian Fluid Mechanics Conference (AFMC)*, Australia, 2012.
- [7] L. Davidson and P.V. Nielsen, "Large Eddy Simulations of Flow in a three-dimensional ventilated room", *5<sup>th</sup> International Conference on Air Distributions in Rooms*, Yokohama, Japan, 1996, pp 161-168.
- [8] J. Tu, G.H. Yeoh and C. Liu, "Computational Fluid Dynamics - A Practical Approach", Butterworth-Heinemann, MA, USA 2008, pp 185-390.