

Range Extended Multi-hop Relay Network with Network Coding Relay

Adisak Sukul and Pattarasinee Bhattarakosol

Abstract— IEEE 802.16j is to enable the operation of multi-hop Relay Stations (RS). It aims to enhance the coverage, per user throughput and system capacity of IEEE 802.16e. However, the Mobile Stations (MSs) which connect to the RS are suffered from exponentially throughput degradation and end-to-end delay increase in congested network. As the number of RS hops increase, so does the degradation and the delay growth, especially on over 3 hops scenarios.

This paper proposes a Network Coding-based Relay scheme for multi-hop relay networks, called NC-based Relay. It allows RSs to combine two wireless backhaul transmissions into one using network coding technique. We also propose an improved OFDMA frame structure design for multi-hop relay network, which provides higher utilization for the relay zone by reorganizing the RSs transmission sequence. The analysis and simulation results confirm that the proposed scheme can enhance the throughput gain up to 140%, and reduce the end-to-end delay by up to 83%.

Index Terms— WiMAX; IEEE 802.16j; Multi-hop Relay Network; Network Coding.

I. INTRODUCTION

IEEE 802.16j [1] is to enable the operation of multi-hop Relay Stations (RS). It aims to enhance the coverage, per user throughput and system capacity of IEEE 802.16e [2]. However, the Mobile Stations (MSs) which connect to the RS are suffered from throughput degradation and end-to-end delay increase [3][4]. As the number of RS hops increase, so does the degradation and the delay growth.

The IEEE 802.16j frame structure standard [1] supports two approaches. The first approach allows one or more RS or MR-BS frames to be grouped into a multi-frame with a repeating pattern of allocated relay zones. This approach causes limitation to the relay zone utilization, especially on over 3 hops scenarios. The second approach enables a single-frame frame structure consisting of more than one relay zones. This approach is appropriated to accommodate the network coding. However, the more RS hops increase, the more relay zones of RSs and MR-BS need to stay in idle mode. This will lead to lower the frame structure utilization and cause throughput degradation.

In this paper, we propose a Network Coding-based Relay scheme, called NC-based relay, and the corresponding frame

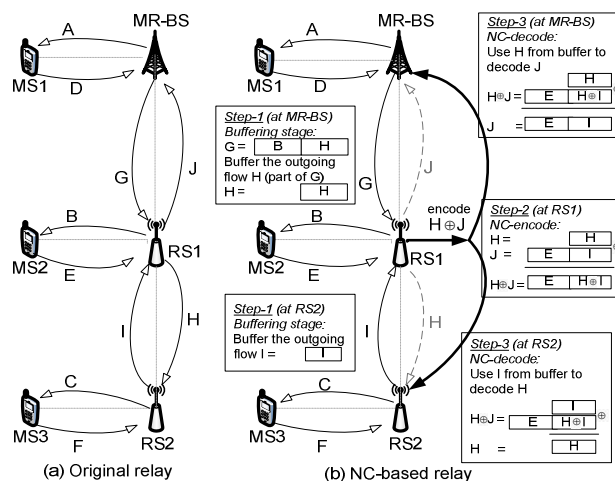

Figure 1. The NC-based relay overview.

structure. This allows RS to combine two sets of data in the wireless backhaul, and transmit it in a single transmission instead of two. As a result, it improves both the throughput and the delay. This is the first time that the network coding has been well studied on IEEE 802.16j Multi-hop Relay Network, and the result shows substantially advantage on multi-hop network over 3 hops scenarios. Table 1 lists all notations used in analysis of the following sections.

II. NC-BASED RELAY AND FRAME STRUCTURE DESIGN

A. NC-based relay Overview

Fig. 1 (a) shows the original RS traffic flows. The operations of RS1 are to receive the traffic flows G and I , and transmit the traffic flows J and H . Fig. 1 (b) shows the traffic flows of the proposed NC-based relay. The operations of RS1 were modified to receive the traffic flows G and I , then transmit only one encoded traffic flow which is $H \oplus J$. The encoded flow $H \oplus J$ is encoded from flows H and I which does not have to be in the same length. When RS1 transmit $H \oplus J$, both the MR-BS and RS2 can overhear the encoded traffic over the wireless backhaul. The RS1 needs only three operations instead of four to complete its task. The NC-based relay process spans over three MAC frames (i.e. frame t , $t+1$ and $t+2$). Fig. 1 (b) shows the example of NC-based relay process, which comprises three operations as follows:

--*Step-1 Buffering stage.* In the frame t , MR-BS transmits the flow G to RS1, and RS2 transmits the flow I to RS1. MR-BS and RS2 will need to buffer the outgoing data of the flow H (part of G) and flow I , respectively. This allows both MR-BS and RS2 to decode the traffic from RS1 in the step-3.

Manuscript received July 25, 2011.

Adisak Sukul is with Department of Computer Science, Faculty of Science, King Mongkut's Institute of Technology Ladkrabang, Bangkok, Thailand. (corresponding author phone: 6681-813-8803; e-mail: ksuaadisa@kmitl.ac.th).

Pattarasinee Bhattarakosol is with Department of Mathematics, Faculty of Science, Chulalongkorn University, Bangkok, Thailand. (e-mail: pattarasinee.b@chula.ac.th).

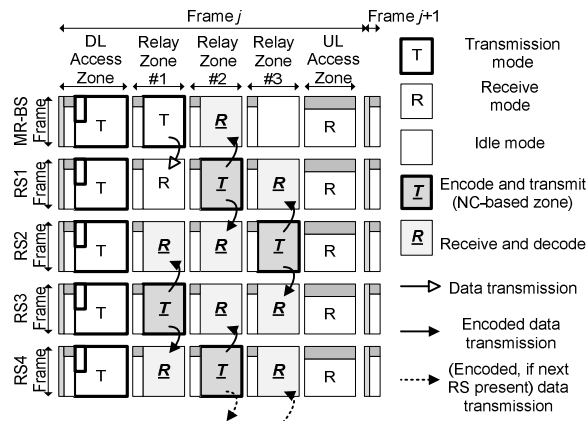

Figure 2. NC-based relay OFDMA frame structure.

--Step-2 NC-encode. In the frame $t+1$, RS1 encodes flows H and J together by the XOR operation. In this operation, right alignment is used for the shorter flow. Moreover, data bits of the longer flow that have no opponent in this XOR operation will leave unencoded. Then, the RS1 will transmit the encoded flow $H \oplus J$ over the wireless channel, which will be overheard by both MR-BS and RS2.

--Step-3 NC-decode. In the frame $t+2$, MR-BS decodes the flow $H \oplus J$ by XOR with the buffered data of the flow H . The decoded result is the data of the flow J . Similarly, the RS2 decodes the flow $H \oplus J$ by XOR with the buffered data from the flow I . The decoded result is the data of the flow H .

B. Frame Structure Design

Fig. 2 shows the proposed frame structure that corresponds to the NC-based relay scheme. Each MAC frame of MR-BS or RS comprises DL access zone, UL access zone and three relay zones. These access zones are used for communicating with their covered MSs. Moreover, the three relay zones are used for MR-BS to communicate with the RS, and used for RS to communicate with their super-ordinate and sub-ordinate RSs.

Fig. 2 also presents the transmission sequence within relay zone. Each zone in the transmission sequence can be in either transmission, receive or idle mode. The NC-based relay can be applied to the transmission mode zone, called the NC-based zone. The transmission sequence of MR-BS is assigned to transmission mode in relay zone #1, the receive mode in the relay zone #2, and idle mode in relay zone #3. The transmission sequence of RS1 is assigned to receiving data from the MR-BS on the relay zone #1. The NC-based zone can be applied to the relay zone #2, which encodes and transmits data to both directions (MR-BS and RS2) in a

TABLE I
NOTATIONS USED

Term	Definition
h	Number of total hop
i	Hop count of from MR-BS to considered RS
w, w_d, w_u	Traffic between MR-BS and each MS, Downlink traffic, Uplink traffic
TP_{MSi}	Average throughput on MS_i
F_d	Frame duration
R_d	Relay zone duration
B_w	Channel bandwidth
RE	Relay zone efficiency
ALD_i	Access link maximum throughput archived
DM_{Si}	Average end-to-end delay on MS_i
DM_i	Base station/Relay station operation delay
DP_i	Propagation delay on access link i
DPR_i	Propagation delay on relay link i

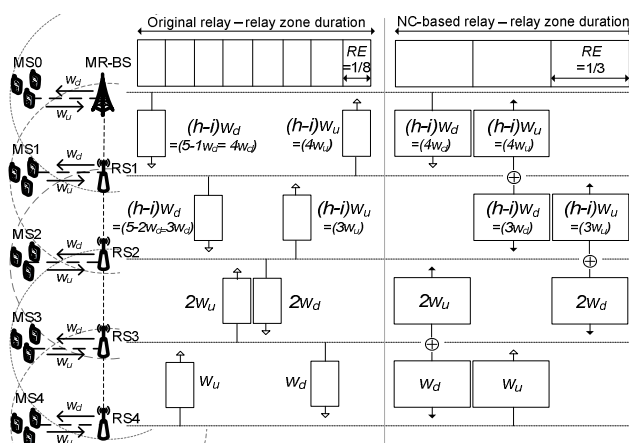

Figure 3. Traffic handled by the relay zone efficiency (RE).

single transmission. The relay zone #3 is to receive and decode an encoded data from RS2. The NC-based zone in each RS transmission sequence is denoted by $RS_{i-NC-zone}$, and can be expressed by

$$RS_{i-NC-zone} = \begin{cases} \text{none} & , i = 0 \\ (i \bmod 3) + 1 & , 0 < i < h \\ \text{none} & , i = h. \end{cases} \quad (1)$$

It is worth noticing that the number of relay zones in the NC-based relay frame is independent to the number of RS hops. However, in the original relay scheme, the idle mode has to be assigned to more zones in the transmission sequence to avoid the transmission interference when the number of RS hops is increased. The idle mode is considered as waste.

III. PERFORMANCE ANALYSIS

We have developed a model to study the throughput degradation and delay increase in IEEE 802.16j Multi-hop Relay Network. For simplicity, we assumed that all MR-BS and RSs operate in the same transmission power and range. Highest modulation is used on all wireless backhaul links. The coverage and interference ranges of each RS can cover super-ordinate RS/MR-BS, sub-ordinate RS and MSs of the RS.

A. Relay zone efficiency

Due to the NC-base relay having higher utilization in the relay zone, it results in higher RE than the original relay. Fig. 3 shows RE of 5-hop scenarios of the original relay and the NC-based relay scheme that are 1/8 and 1/3, respectively. The RE of the original relay scheme can be expressed by

$$RE = \frac{1}{2(h-1)} \quad (2)$$

The RE of 3-hop and 4-hop scenarios of the original relay scheme are 1/4 and 1/6, respectively. On one hand, when more RS hops are added to the scenario, RE will decrease in the case of original relay scheme. On the other hand, RE for NC-based relay is always 1/3 and independent from number of RS hops.

B. Throughput Analysis

The fair comparison between the NC-based relay and the original relay scheme was created by making the size equal for following parameters: F_d , R_d and w . We assumed that the ratio of $\frac{w_d}{w}$ and $\frac{R_d}{F_d}$ are both 1/2. The TP_{MSi} of the downlink traffic can be expressed by

$$TP_{MSi} = \begin{cases} \left(\frac{F_d - R_d}{F_d}\right)\left(\frac{W_d}{W}\right) \cdot Bw & , i = 0 \\ RE \cdot \left(\frac{R_d}{F_d}\right)\left(\frac{W_d}{(h-1)Wd}\right)\left(\frac{Bw \cdot F_d}{i}\right) & , i > 0. \end{cases} \quad (3)$$

Note that in (3), the maximum traffic handled by the relay link is given by $\left(\frac{W_d}{(h-1)Wd}\right)$. The end-to-end data rate through the multi-hop link is given by $\left(\frac{Bw \cdot F_d}{i}\right)$. The end-to-end throughputs of 3-5 hops scenarios are shown in Fig. 4 (a).

C. End-to-end Delay Analysis

The proposed NC-based relay and the frame structure can reduce the end-to-end delay. By reordering the transmission sequence of RSs, they allow traffic flow to travel up to 3 RS hops in single MAC frame. The result shows that they reduce the delay in case of multi-hop flow by up to 3 MAC frames duration. Hence, the value of i' is equal to i in original relay scheme. However, in NC-based relay, value of i' is equal to $(i \text{ div } 3)$. Average end-to-end delay on each hop can be expressed by

$$D_{MSi} = \begin{cases} DM_0 + DP_0 & , i = 0 \\ \left(i_r F_d\right) + \sum_{j=0}^i DM_j + \sum_{k=0}^{i-1} DPR_k + DP_i + \left(\left[\frac{wd}{(h-1)wd}\right] F_d \cdot RE\right) & , i > 0 \end{cases} \quad (4)$$

Note that in (6), the delay from the multi-hop frame structure is given by $(i_r F_d)$. The traffic delay, which is the time that RSs need to clear their buffers, is given by $\left(\left[\frac{wd}{(h-1)wd}\right] F_d \cdot RE\right)$. The operation delay and propagation

delay are given by $\sum_{j=0}^i DM_j$ and $\sum_{k=0}^{i-1} DPR_k + DP_i$, respectively.

IV. EXPERIMENTAL RESULT

In this section, we present the simulation results to demonstrate the performance of the proposed scheme. QualNet 4.0 was extended to support the multi-hop relay function.

A. Simulation Model

To represent a realistic IEEE 802.16j Multi-hop Network, our simulation model has six scenarios which are 3-hop, 4-hop, and 5-hop scenarios with and without the NC-based relay scheme. Each MR-BS/RS covers 20 MSs. Each MS communicates to the MR-BS with similar traffic. Fig. 3 shows an example of 5-hop scenario configuration. We use the following parameters in the simulation: 300s of traffic flows generated, 64QAM modulation, 20ms for frame duration, 10us for TTG/RTG, 4us for SSTG, Pareto distribution 32-2048 bytes for data size and Poisson distribution arrival with 0.1ms mean interval.

B. Simulation Results

Fig. 4(a) shows a significantly higher throughput of the NC-based relay comparing with the original relay scheme.

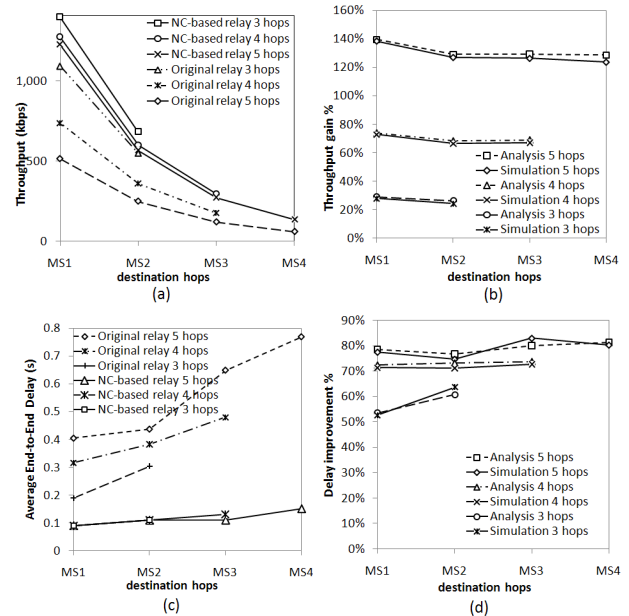

Figure 4(a). Throughput (kbps) (b) Throughput gain% (c) Average end-to-end delay (d) Delay improvement.

Fig. 4(b) shows the throughput gain from the simulation result comparing with the analysis result in (3). The throughput gain is 24-28% on 3-hop scenario, 67-73% on 4-hop scenario and 124-140% on 5-hop scenario. Fig. 4(c) shows a significantly lower end-to-end delay of the NC-based relay comparing with the original relay scheme. Fig. 4(d) shows the delay improvement from the simulation result comparing with the analysis result in (4), which is equal to 53-64% on 3-hop scenario, 71-73% on 4-hop scenario and 75-83% on 5-hop scenario. Fig. 4(b) and Fig. 4(d) also show that there was no significant difference between the analysis and the simulation results, which confirms the accuracy of our analysis.

V. CONCLUSION

In this paper, we propose a Network Coding-based Relay scheme and the corresponding frame structure that uses XOR network coding. This allows each RS in the multi-hop network to combine two set of data in wireless backhaul, and transmit it in a single transmission instead of two. As a result, it improves both the throughput and the delay. Simulation and analysis results confirm that our proposed scheme can enhance up to 140% of throughput gain and can reduce the end-to-end delay by up to 83%. Due to the operations in the proposed scheme are simple to RSs, the proposed scheme can be a practical implement to the IEEE 802.16j multi-hop network.

REFERENCES

- [1] IEEE Standard for Local and metropolitan area networks. Part 16: Air Interface for Broadband Wireless Access Systems Amendment 1: Multiple Relay Specification, IEEE 802.16j, June 2009.
- [2] IEEE Std 802.16e-2005, "Part 16: Air interface for fixed and mobile broadband wireless access systems," Feb 2006.
- [3] P.C. Ng and S.C. Liew, "Throughput analysis of IEEE802.11 multi-hop ad hoc networks," IEEE Trans. Netw., vol.15, no.2, pp.309-322, 2007.
- [4] Z. Tao, A. Li, K.H. Teo, J. Zhang. Frame Structure Design for IEEE 802.16j Mobile Multihop Relay (MMR) Networks. In Proc. of IEEE GLOBECOM 07, Washington, DC, 2007.